

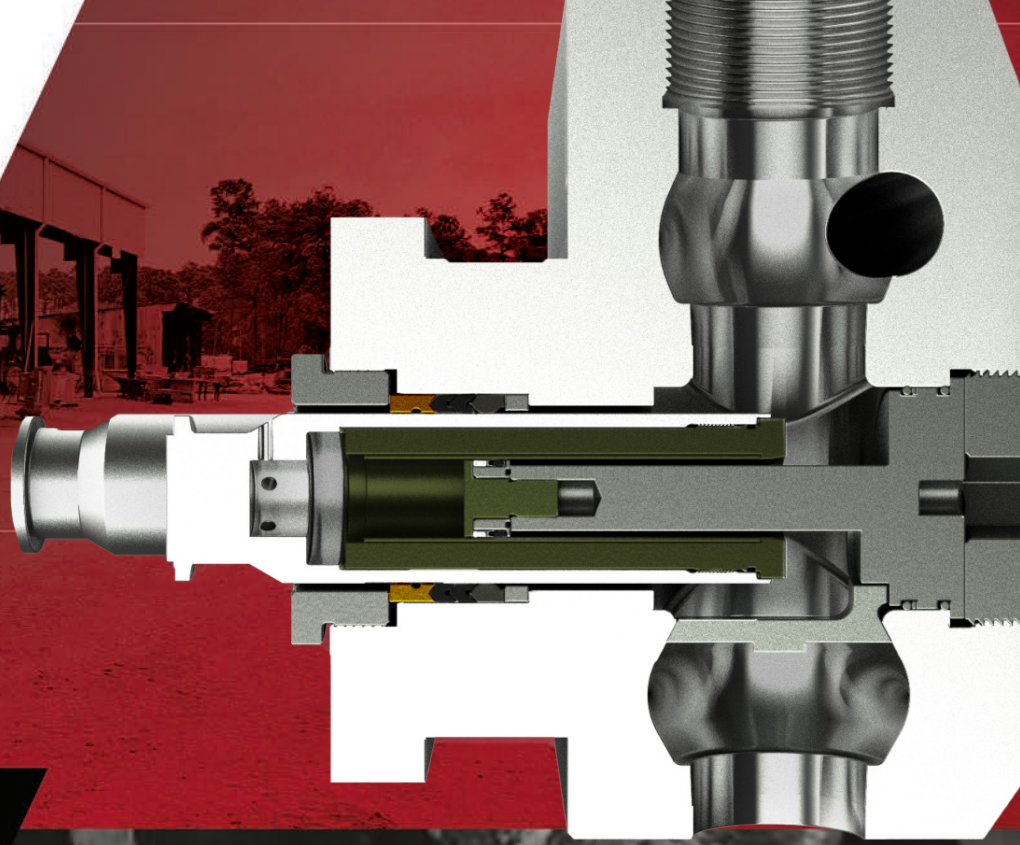

**SOUTHERN**  
STIMULATION TECHNOLOGIES

# ONE-N-DONE

Flexible flow rates  
regardless of your fluid end  
size.



*It's just that easy...*

Southern Stimulation's proprietary patent pending adjustable plunger and liner system alters the overall displacement giving customers the ability to pump under pressure while lowering the powered rod-load.

Powerful in performance, Southern's One-N-Done Technology replaces the job of multiple frac fluid ends which gives customers the ability to have the performance of three fluid ends in only one package. By removing the current constraints of having to own separate fluid ends for different rate and pressure requirements, this new technology lowers power abuse and decreases maintenance cost by lowering the number of fluid end sizes needed, yet achieving lower rate or in between pressures that mechanically was never possible before.

Southern's smarter thinking now gives Well Service Companies an alternative solution for plunger size adjustments. Before now, companies were limited in options as far as plunger size, displacement, and pressures. But with Southern's One-N-Done technology, companies can now utilize this adjustable plunger system customized flow. The ONE-N-DONE, drops the operational rod load down to 80%, which is 15% lower than the industry standard, by operating with less strain and abuse on the power end.

#### KEY BENEFITS:

- Customizable discharge flow rates
- Lowered operating rod-load
- Replace sleeve to adjust plunger size (fluid end swap)

*One-N-Done Technology can be adapted to nearly any make and model pump available on the market today.*

#### Compatible Well Service Pumps:

- Demay: HD-500,
- AXON: HD-500, HD-1000
- GD: GD-2250T, GD-2500Q, C-2500, GD-3000
- SPM: TWS 2250, QWS 2500
- OFM: 2250, 2500Q

