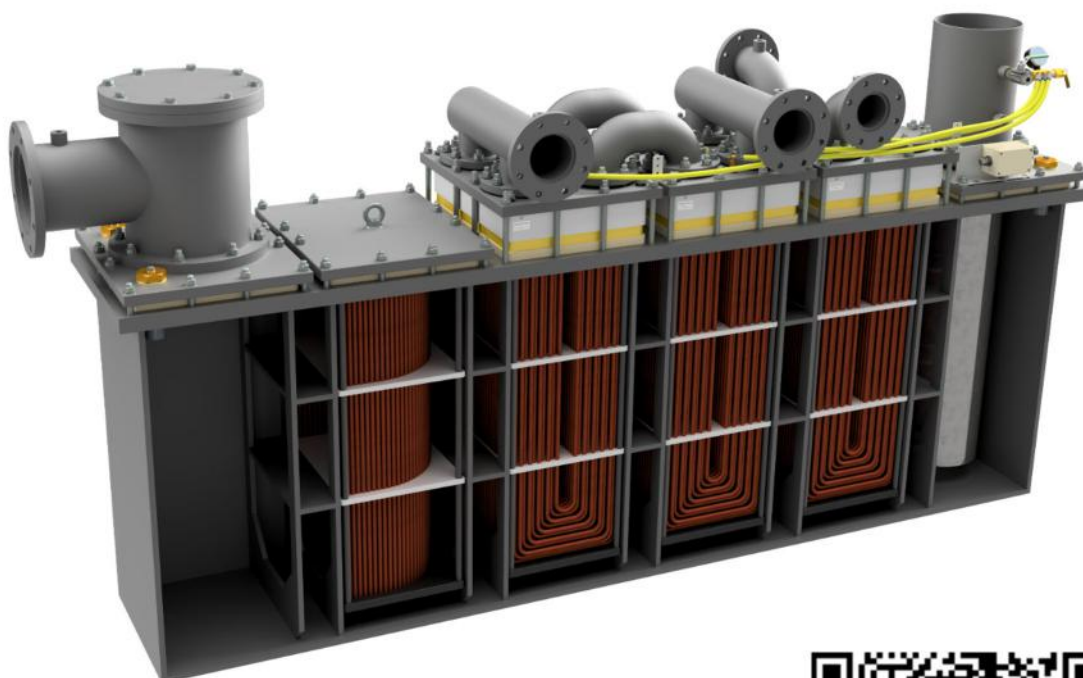

USER MANUAL

RACK COOLER

TYPE: 600S

REVISION: E

REVISION DATE: 04.01.2023



CONTENT

| | |
|---|-----------|
| RACK COOLING SYSTEM - GENERAL INFO | 4 |
| <i>Purpose</i> | 4 |
| <i>Personal safety</i> | 4 |
| <i>Warranty</i> | 4 |
| START-UP AND COMMISSIONING | 5 |
| <i>Ventilation</i> | 5 |
| <i>Frequency controller (VFD) for seawater pumps</i> | 5 |
| <i>Seawater flow</i> | 5 |
| <i>Start-up procedure and running in sequence</i> | 5 |
| <i>Insulation Guard</i> | 6 |
| <i>Verification</i> | 6 |
| <i>Design criteria</i> | 6 |
| <i>Maintenance prior to vessel delivery</i> | 6 |
| OPERATION | 7 |
| <i>Ventilation</i> | 7 |
| <i>SW System</i> | 8 |
| <i>FW System</i> | 8 |
| <i>Insulation guard</i> | 9 |
| MAINTENANCE..... | 10 |
| <i>Maintenance routines</i> | 10 |
| <i>Required maintenance schedule</i> | 11 |
| <i>3-way valve – Ventilation kit – Normal running/ Cleaning</i> | 14 |
| <i>How to run the flushing cycle:</i> | 15 |
| <i>How to run the cleaning cycle:</i> | 15 |
| <i>How to empty the Rack case:</i> | 15 |
| <i>Lifting instructions</i> | 16 |
| DISASSEMBLING/ ASSEMBLING OF RACK BUNDLE..... | 17 |
| <i>Seawater (SW)</i> | 17 |
| <i>Freshwater (FW)</i> | 17 |
| <i>Rack bundle – Assembly direction – 4-pass solution</i> | 18 |
| <i>Rack bundle – Assembly direction – 6-pass solution</i> | 19 |

| | |
|---|-----------|
| <i>Re-assembling the Rack bundle</i> | 20 |
| <i>Cleaning procedure</i> | 21 |
| <i>Cleaning process performed onboard or quayside with environmentally friendly liquids</i> | 22 |
| <i>Torques</i> | 24 |
| <i>Recommended Spare parts – Rack 600S</i> | 26 |
| FAULT FINDING AND TROUBLE SHOOTING | 29 |
| <i>Rack insulation guard</i> | 29 |
| <i>Ventilation kit</i> | 29 |
| <i>Cooling</i> | 29 |
| <i>Leakages</i> | 30 |
| How to check internal leakage in Rack bundle | 31 |
| How to plug a broken tube on a Rack bundle..... | 32 |
| PART LIST & ILLUSTRATIONS | 33 |
| Top plate for seawater inlet..... | 34 |
| Top plate for seawater outlet | 35 |
| Blind plate/ Top plate for Protection unit | 36 |
| Top plate for Rack bundle | 37 |
| Rack bundle | 39 |
| Ventilation kit and hoses | 40 |
| Protection unit (Option)..... | 41 |
| Filter unit (Option) | 42 |
| HOW TO ORDER SPARE PARTS | 43 |
| ADDITIONAL INFORMATION | 43 |

RACK COOLING SYSTEM - GENERAL INFO

Purpose

Hydroniq has produced this manual to provide information for all users of the cooler equipment. This includes information about the cooler's construction and operation, as well as basic information regarding inspection and maintenance.

It is important that operators familiarize themselves with the contents of this user manual to ensure that use and maintenance work are carried out in the correct and safe manner.

The maintenance intervals are based on experience and may vary depending on the cooler's operational parameters.

The supplier accepts no responsibility for damage resulting from careless operation or inadequate maintenance. Keep the cooler in good mechanical condition and remember that preventive maintenance of the equipment reduces the danger of damage and unnecessary operational interruptions.

Hydroniq reserves the right to modify details without prior warning.

Check our web page: www.hydroniq.no for the latest version of this User manual.

Personal safety

Please make yourself familiar with the content in this user manual before operating the cooler.

It is the responsibility of the user to ensure that appropriate controls and precautions are identified and applied in relation to the work envisaged by this document in accordance with relevant statutory, legal and industry requirements to protect the health and safety of the persons undertaking the work.

All operation and service of the cooler is to be carried out by personnel who are familiar with the contents of this manual.

Unauthorized changes or modification of the cooler may result in a safety hazard and is not permitted.

Warranty

Please note that the warranty will be void if the equipment is misused or not handled in accordance with prescribed operating and service standards.

Failure to follow these operating guidelines and principles, or unauthorized changes or modification of the cooler and its components will void the warranty.

The Hydroniq Rack coolers has a limited warranty that is valid only with use of original spare parts purchased from Hydroniq Coolers AS.

Hydroniq RACK cooler is a module-based system, built up by several U-bundles. Since it can be difficult to change a broken tube in a U-bundle, Hydroniq Coolers always adds an extra 3% cooling surface in the capacity calculations, in case of broken tubes during production, installation or start-up. The extra margin in the calculation, and extra tubes installed, will allow for plugging several tubes in service. With up to 2% plugged tubes in a RACK-bundle, Hydroniq Coolers guarantees a 100% cooling capacity as designed and according to design criteria, and therefore consider the bundle as a full worthy product.

START-UP AND COMMISSIONING

Procedure to be used at start-up and commissioning of a new system and after replacement and start-up of new/overhauled bundles.

Ventilation

Make sure that piping system is properly ventilated and without any "air pockets" in the seawater pipes.

Make sure that the Rack cases are properly ventilated by use of the Rack ventilation kit. Also make sure there is no air in the seawater outlet pipe.

Frequency controller (VFD) for seawater pumps

Ensure regulation setting of the VFD. Verify that % operation is corresponding to frequency and corresponding pump capacity from the pump specification/curve.

Seawater flow

Verify and log correlation between pump speed and flow. Check VFD operation e.g. 25% is corresponding to actual seawater flow of 25%. To be verified by clamp on flowmeter and documented.

Seawater circulation (cold side) shall always be in operation before hot fluid circulation.

Hydroniq can be of assistance for a check of seawater flow, if needed.

Start-up procedure and running in sequence

Please note the following requirements:

First 3 weeks: max 50% flow

Note!

This running in sequences is very important to assure the oxide layer (protective layer) on the tubes will be formed.

Insulation Guard

Confirm installation and operation of insulation guard, and no active alarms.

Verification

Verify water pressure at pump inlet with pump in standstill condition and valves open. This to be verified after completed ventilation procedure.

Log seawater inlet and outlet temperature.

Log freshwater temperature.

If several Rack systems installed, verify, and monitor difference between systems. Ensure same operation patten between both systems.

Look for abnormal vibrations and/or noise.

Design criteria

Design pressure inside tubes: 6 Bar

Design temperature: 0-95°C

Max. flow according to individual project design calculation.

Caution!

During stand still for more than 7 days, the Rack case must be drained for seawater.

If this is not possible, run seawater through the Rack system at least every 7 days (approx. 10 min, 50 % flow).

Maintenance prior to vessel delivery

If the Rack systems is going to be in continuous operation prior to vessel delivery, it is important that the maintenance routines for the product set forward in the User Manual is followed. If water conditions are unfavourable in terms of polluted or dirty water, maintenance intervals need to be adjusted accordingly.

User Manual can also be found on www.hydroniq.no.

OPERATION

Ventilation

Install the ventilation kit and ventilation hoses according to this picture.

The function of this kit is to remove all air pockets from the Rack case.

For more information, see chapter “3-way valve – Ventilation kit – Normal running/ Cleaning”.

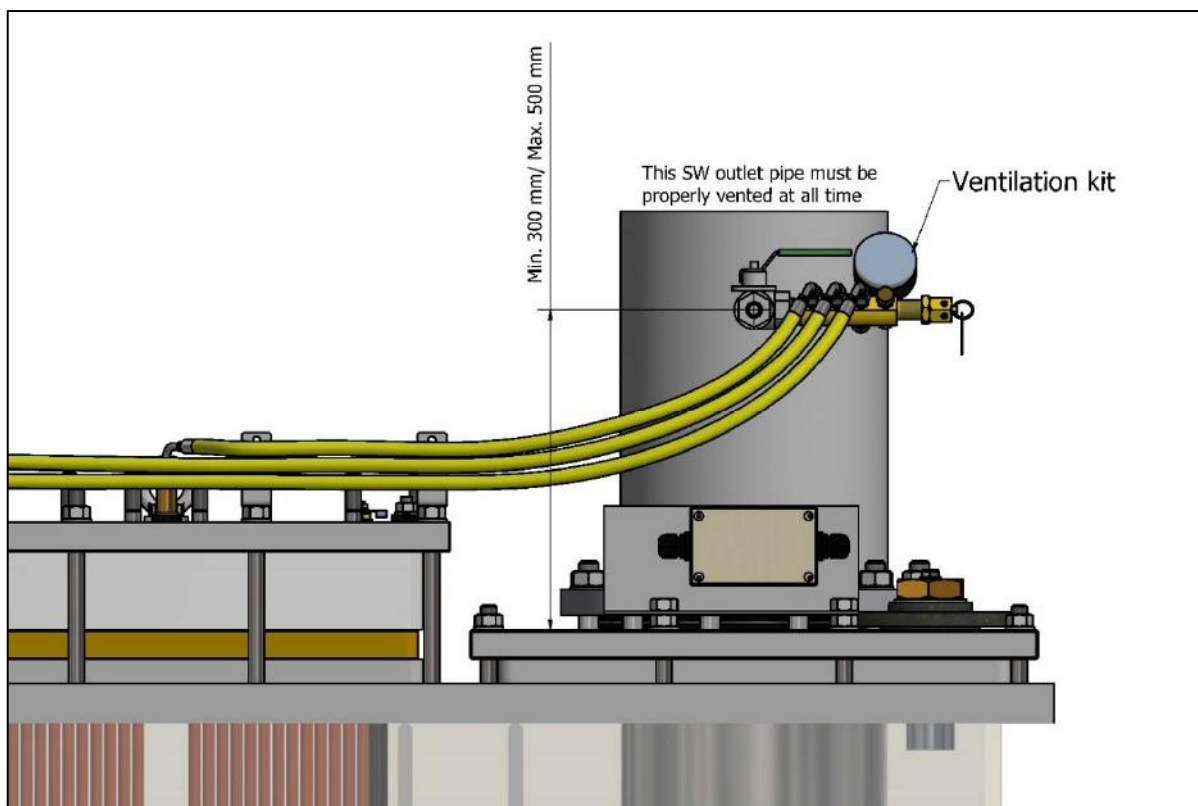

Caution!

It is very important that the Rack ventilation kit is installed correctly to prevent air in seawater. Air in seawater will prevent the creation and maintenance of a good oxide layer, and this can cause serious corrosion problems.

In addition, the air can cause vibrations that will make the tubes less resistance of corrosion, and in some cases, it can lead to fatigue.

It is also important that the seawater piping is proper ventilated.

SW System

Seawater flow shall never exceed the max. flow according to individual project design calculation. For the actual design data sheet(s) for your project; Check the Installation manual, Part 4, Appendices, Appendix 1, Chapter 4.1.8.

If frequency controller (VFD) for seawater pumps is installed, ensure regulation setting of the VFD. Verify that % operation is corresponding to frequency and corresponding pump capacity from the pump specification/curve.

For example: Is 100% equal 60 Hz and thereby 100% pump capacity? (in some cases, VFD is set to 75% equal 60 Hz and thereby 100% pump capacity). This is important information and needs to be confirmed and documented.

VFD ramping up sequence. Ensure that the pump speed is ramping up and not starting at 100% for later ramping down to for example 25%. Repeated sudden starts at 100% is not acceptable.

Check pump operation if multiple pumps are installed. Verify different operation modes. If operation mode allows for 2 pumps operating in parallel, seawater flow shall never, at any time, exceed maximum design level.

Hydroniq can be of assistance for verification test, if needed.

Seawater circulation (cold side) shall always be in operation before hot fluid circulation.

FW System

All additives must be compatible with Cu/ Ni tubes.

If there are particles bigger than 5 mm in the freshwater, a filter must be mounted before the Rack bundle.

The in-/ outlet valves must be close to but located at the outside of the Rack bundle top plate.

All FW piping's and blind flanges on the Rack bundles must have the possibility to be ventilated.

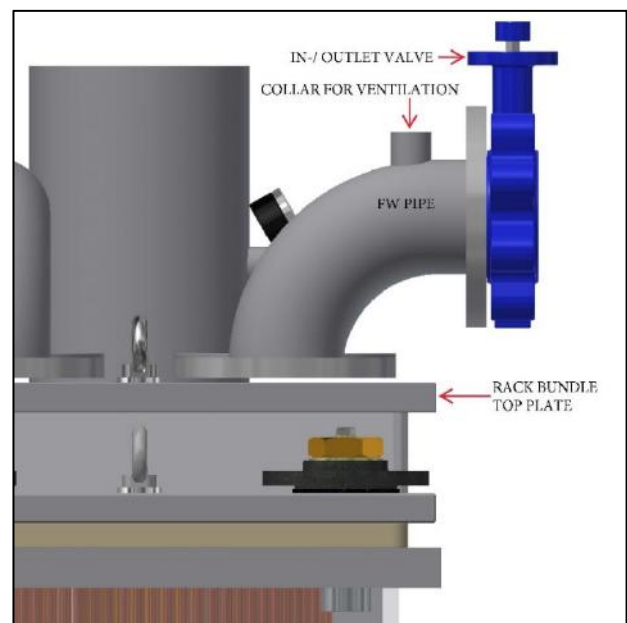

Insulation guard

Program description

The PLC is programmed to monitor the Hydroniq Rack Cooler. Each bundle is separately monitored and has an individual error message. Error messages are displayed in the control panel. The monitor runs a test run once a day if auto is activated and a manual test run can be initiated by pressing F1. Press F4 for light in the display.

PLC Configurations

Clock settings:

1. Open the Insulation cabinet door
2. Find the Siemens Logo display
3. Press "arrow down"
4. Then "ESC"
5. Choose "Setup" and press "OK/Enter"
6. Choose "Clock" and press "OK/ Enter"
7. Choose "Set clock" and press "OK/ Enter"
8. Use the arrows to set the correct time and date
9. Press "ESC"



Number of bundles:

Change the number of bundles the PLC can monitor (from 1 to 7 bundles):

1. Press "arrow down"
2. Then "ESC"
3. Choose "Program" and "Enter"
4. Set Param press "Enter"
5. Scroll down to you see "NRofBund" press "Enter"
6. In the field "On", press "Enter", then "arrow right" to the last number.
7. Choose the number of Bundles that your Rack system has by pressing the "arrow up or down".
8. Press "Enter"
9. Press "Esc" four times, and "arrow up"

User description:

To start testing the Rack for insulation faults:

1. Press F1 and the display will show "TESTING"
2. The PLC is testing each bundle on the Rack.
3. Wait for the test to finish. If the PLC finds any faults it will display error message in the front display, and it flashes red.
4. To toggle Auto testing, press F2.
5. When the display shows "Auto is on" the PLC test once every TL value on block 22 (default 12Hours)

MAINTENANCE

Maintenance routines

The following is a guideline for a normal maintenance schedule. However, the Rack Coolers operating conditions vary widely from installation to installation, and it is therefore important to adapt the maintenance schedule to the experience of the individual operator.

Note!

Sacrificing anodes must be inspected at least every third month until rate of consumption is established.

Rate of anode consumption is dependent of quality of fluid, pipe system and machinery connected to Hydroniq Rack cooler.

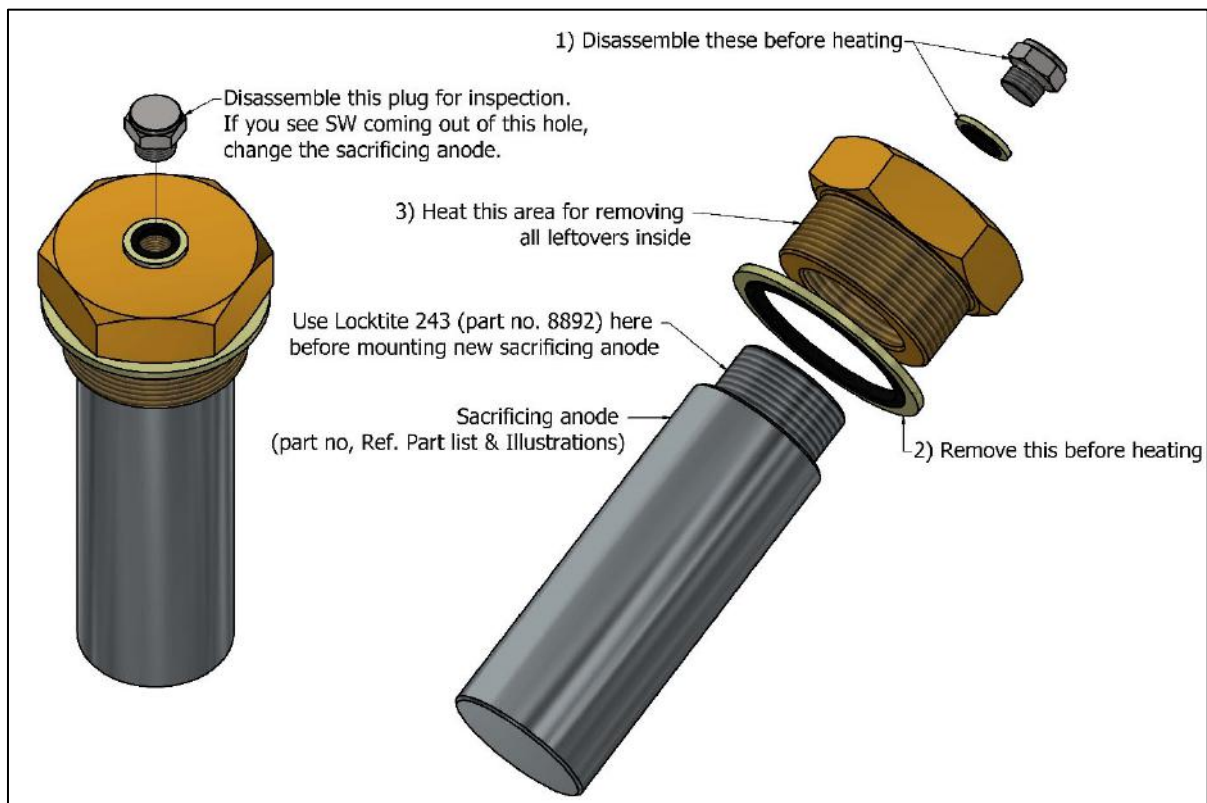

Note!

Damage caused by insufficient anodic protection is not covered by the warranty. Hydroniq Rack cooler may need cleaning at regular intervals based on service experience.

Required maintenance schedule

| No. | Task | Weekly | 1 month | 3 months | 6 months | 12 months | 30 months | 60 months | 120 months |
|-----|--|--------|---------|----------|----------|-----------|-----------|-----------|------------|
| 1 | Filter-unit (if applicable) | X | | | | | | | |
| 2 | Flushing (Max. 10 min.) | | X | | | | | | |
| 3 | Visual inspection | | X | | | | | | |
| 4 | Check Insulation guard | | X | | | | | | |
| 5 | Sacrificing anode inspection | | | X | | | | | |
| 6 | Cleaning cycles (Max. 30 min.) | | | X | | | | | |
| 7 | Check the nuts | | | X | | | | | |
| 8 | Protection unit inspection (if applicable) | | | | X | | | | |
| 9 | Replace sacrificing anode | | | | | X | | | |
| 10 | Sacrificing T-piece inspection (if applicable) | | | | | X | | | |
| 11 | Replace the sacrificing T-piece at filter unit (if applicable) | | | | | | X | | |
| 12 | Replace ventilation kit | | | | | | X | | |
| 13 | Replace ventilation hoses and parts | | | | | | X | | |
| 14 | Main class overhaul | | | | | | | X | |
| 15 | Replacement of all bundles and parts | | | | | | | | X |

- 1) See next page if you have installed this filter unit at seawater inlet position.
- 2) Run the flushing cycles once a month. (See page 15 for instruction).
- 3) Check for leakages at the ventilation kits and around each Rack systems.
- 4) Press F1 on the insulation guard for a manual test. (Press F4 for light at the display).
- 5) See page 10 for instructions.
- 6) See page 15 for instructions.
- 7) Re-tighten all nuts with the correct torque (see torques at page 24).
- 8) Before inspection, empty the Rack case. (See page 15 for instructions). Remove the protection unit top plate. Check inside the protection unit for dirt.

- 9) Replace the sacrificing anodes at least once a year.
- 10) Remove the 8 pc. M16 nuts on the amplifier for the filter unit and lift up the filter unit by the lifting eye. Check inside the T-piece. (If applicable).
- 11) Replace the sacrificing T-piece at filter unit (if applicable).
- 12) Replace the ventilation kit (part no. 8666).
- 13) Replace the ventilation hoses and parts.
- 14) Follow the Hydroniq overhaul procedure.
- 15) Follow the Hydroniq procedure.

No. 1 (if applicable)

It is recommended to lift up the floater (part no. 8738-08) by the manual handle (part no. 8734) once a week (when SW pump is running at low speed).

Normal operation

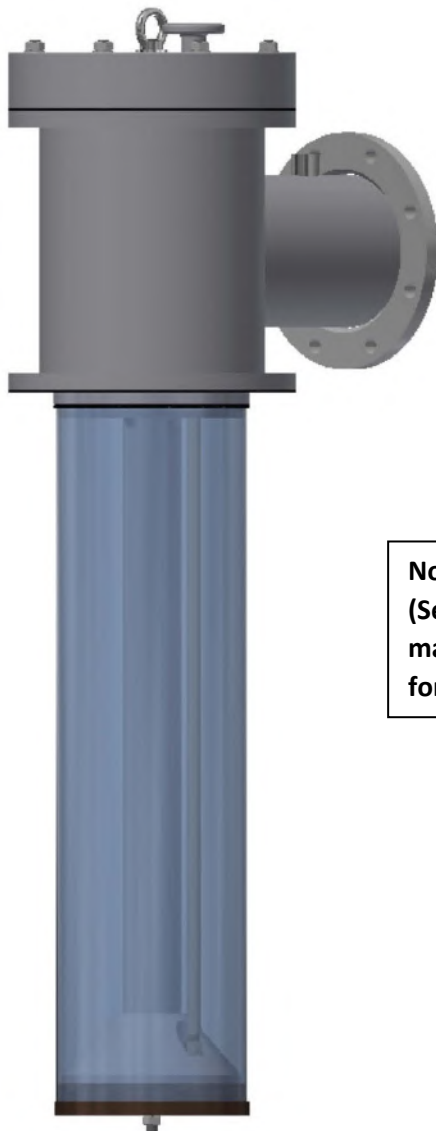

Cleaning the filter

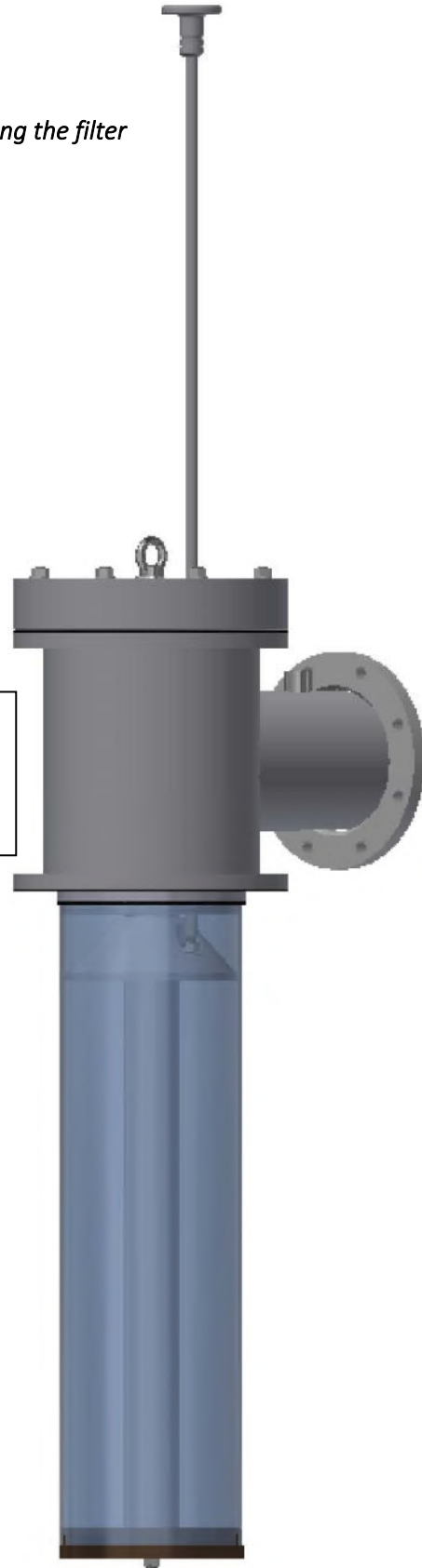

**Note! Sacrificing T-piece.
(See required
maintenance schedule
for this T-piece)**

3-way valve – Ventilation kit – Normal running/ Cleaning

Normal running

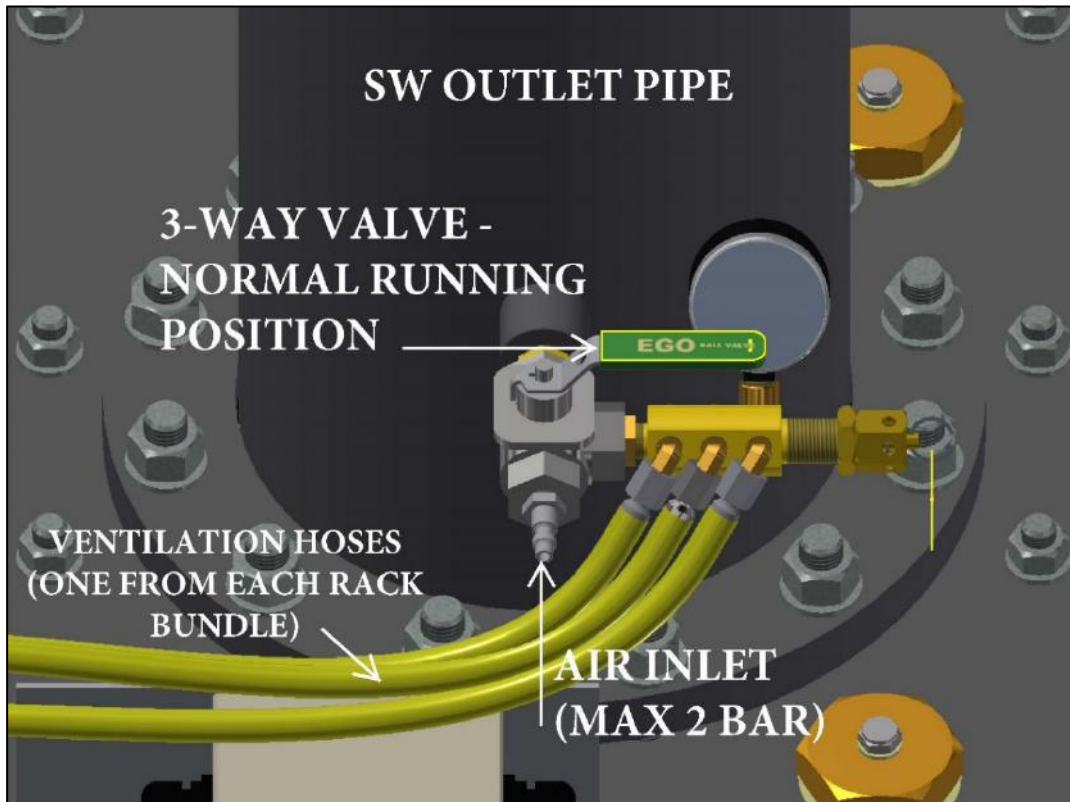

Cleaning/ Emptying

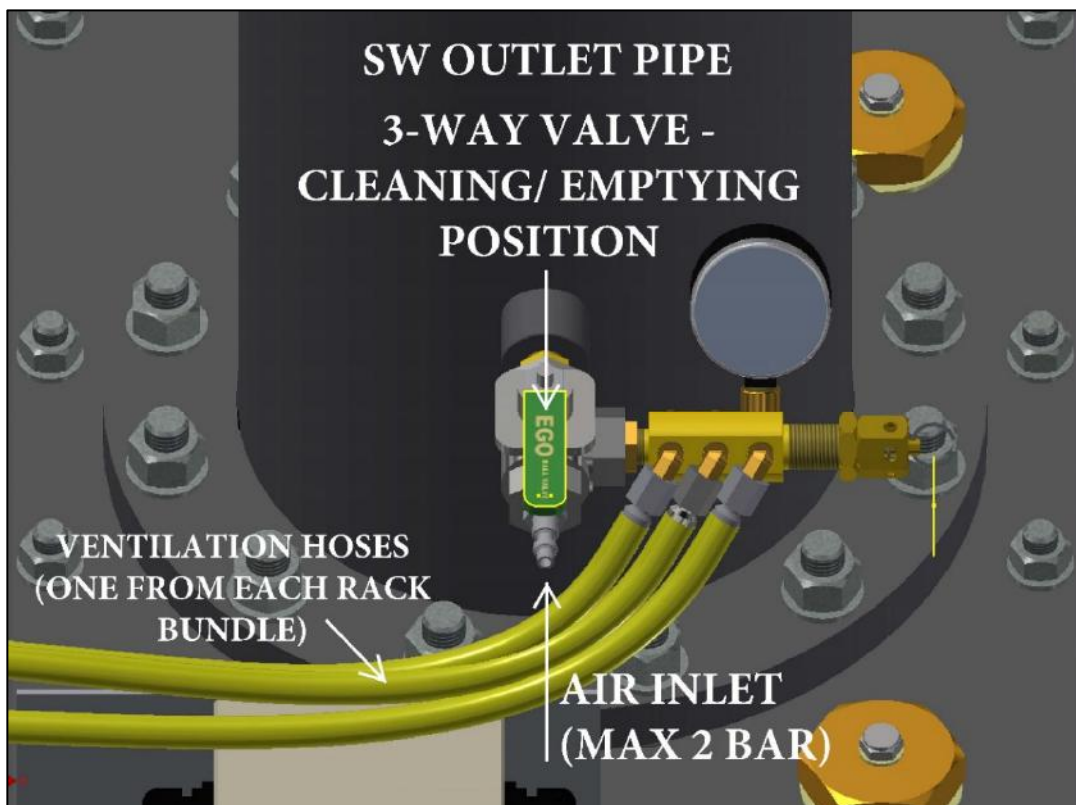

How to run the flushing cycle:

1. Run seawater pump at max. calculated flow (Check the Installation manual, Part 4, Appendices, Appendix 1, Chapter 4.1.8).

How to run the cleaning cycle:

1. Connect air to the ventilation kit (max. 2 bar)
2. Run seawater pump at max. calculated flow (Check the Installation manual, Part 4, Appendices, Appendix 1, Chapter 4.1.8).
3. Open the 3-way valve at “cleaning” position (see picture on previous page) for max 30 minutes.
4. Disconnect air hose from the 3-way valve
5. Turn the 3-way valve at “Normal running” position (closed) after seawater comes out of the air hose connection.
6. **Make sure that all air has been ventilated from the Rack case.**

How to empty the Rack case:

1. Close the seawater inlet valve
2. Connect air to the ventilation kit (max. 2 bar)
3. Open the 3-way valve at “cleaning” position
4. When the Rack case is empty, close the 3-way valve by turning it to “Normal running” position
5. Close the seawater outlet valve
6. Disconnect air from the ventilation kit
7. To release the air from Rack case, turn the 3-way valve to “Cleaning” position

Warning!

Make sure there is no pressure in Rack case before starting; disassembling the Top plates/ Rack bundles/ Sacrificing anodes.

Ventilation kit

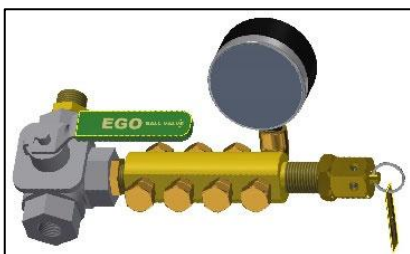

Caution!

The air inlet connection on the ventilation kit should not be blocked. If this is blocked, and the 3-way valve is in cleaning/ flushing position when starting the SW pumps, automatic ventilation of the Rack case will not work, and air will accumulate in the Rack case.

The system is now ready for inspection/ maintenance. Start checking the Rack bundle located nearest SW inlet.

Yearly inspections are recommended in order to establish fouling rate.

Lifting instructions

Warning!

The weight of the Rack bundles must always be checked before attempting to lift, to ensure that the lifting equipment is certified to carry the actual load. The weight of the Rack bundle you will find in the Installation manual, Part 4 – Appendices - Appendix 1 - 4.1.6.

When in need of lifting the Rack bundles, the following instructions must be followed:

- Close the FW in- and outlet valve
- Remove all FW piping from the actual bundle(s)
- Remove the ventilation hose
- Remove the Insulation guard wire at the top plate
- Always lift by the lifting eye located on the Rack bundle top plate
- Always check that the lifting eye is tighten before you start lifting
- Use a certified shackle and strap



DISASSEMBLING/ ASSEMBLING OF RACK BUNDLE

If a Rack bundle must be disassembled for inspection or servicing, it is recommended to work according to following sequence:

Seawater (SW)

- Close the seawater inlet valve.
- Connect air hose at 3-way valve (max. 2 bar)
- Open the 3-way valve at “cleaning” position. This will empty the Rack case for seawater.
- Close the SW outlet valve when all SW is drained. This takes approx. 20-40 min.
- Turn the 3-way valve at “Running” position (closed).
- Disconnect the air hose at 3-way valve.
- Open the 3-way valve at “cleaning” position and evacuate all air thru the 3-way valve.
- Make sure there is no pressure in the system before disassembling the Rack bundle.

Freshwater (FW)

- Close in/ outlet valves.
- Make sure there is no pressure in the FW piping before disassembling the two ¼” BSP plugs at the FW top plate.
- Install the plastic tubes (part no. 8905-P, supplied by Hydroniq) according to below picture.
- Use service air to evacuate the glycol/ freshwater (max 2 bar).

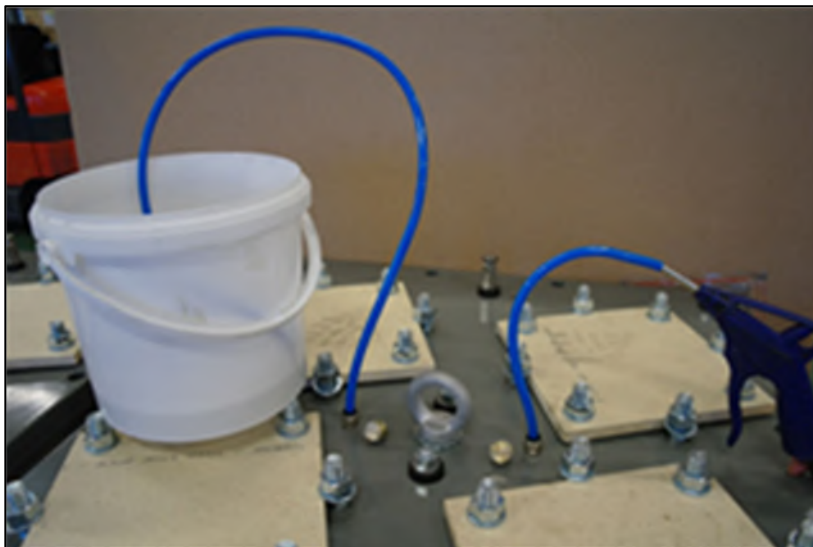

Rack bundle – Assembly direction – 4-pass solution

Distribution frame (1): The sticker and the hole (2) indicate that the piece (3) shall point towards seawater inlet.

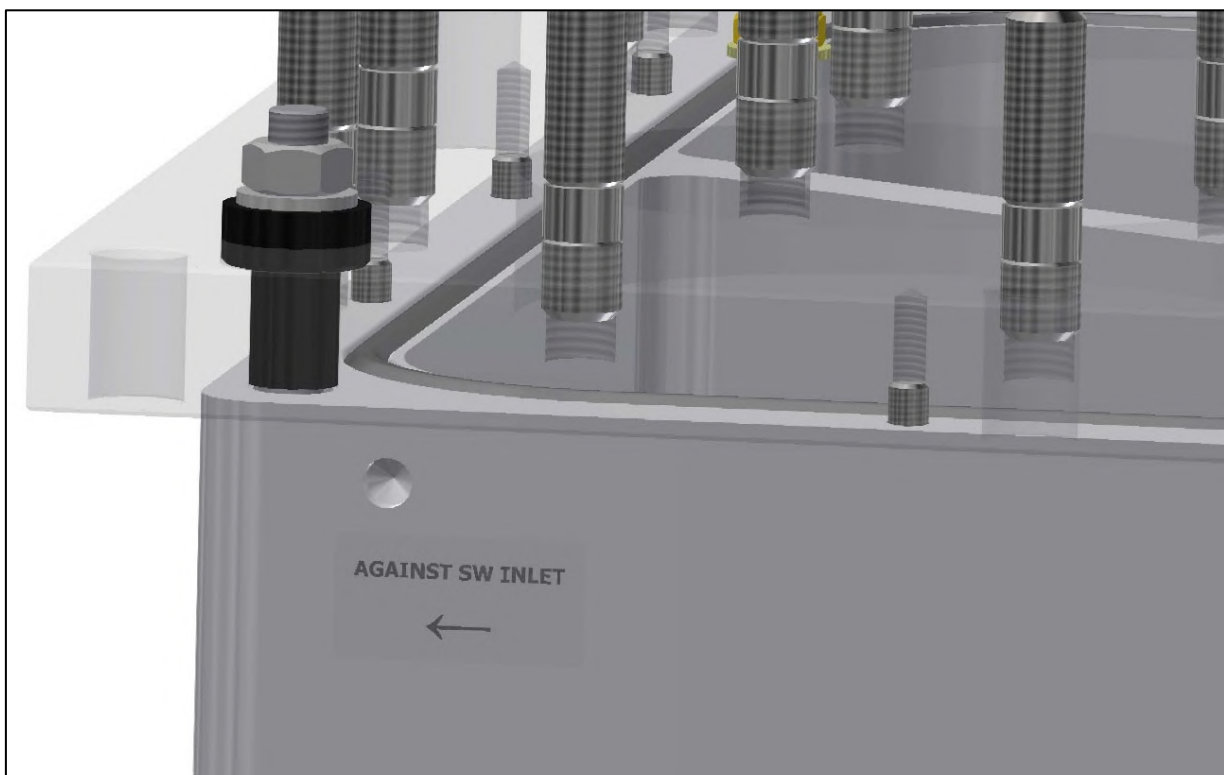
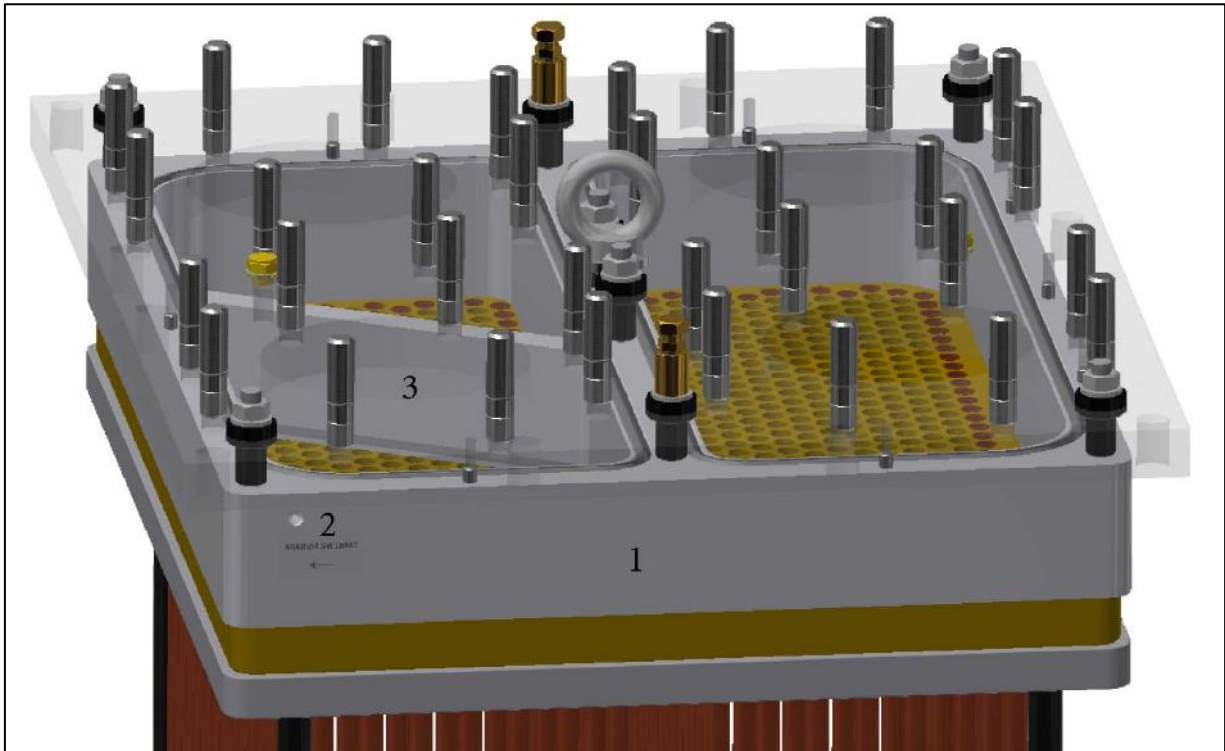

Rack bundle – Assembly direction – 6-pass solution

Distribution frame (1): The sticker (2) indicate that the piece (3) is the side where you must connect the FW inlet connection.

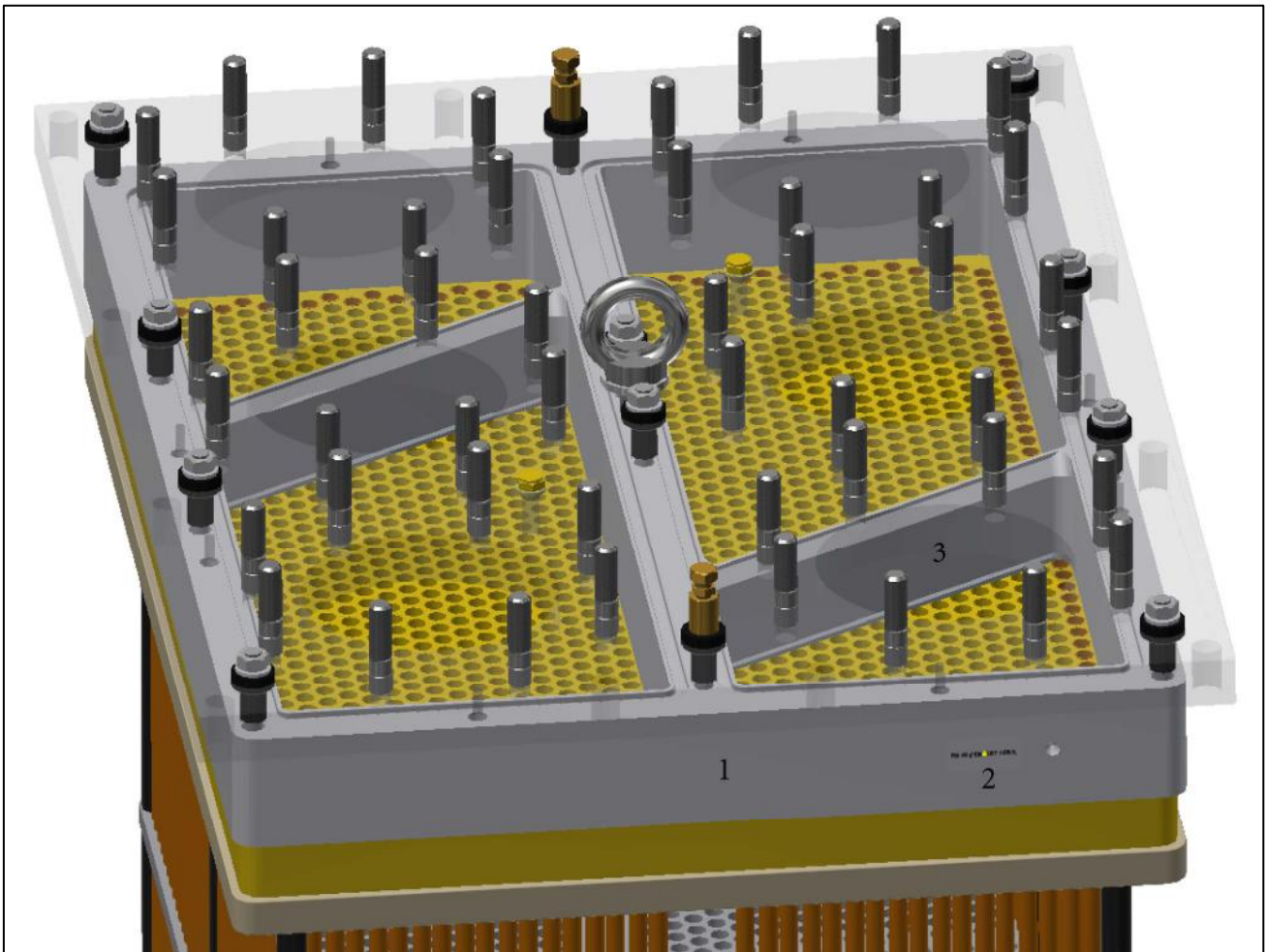

Re-assembling the Rack bundle

- Check that surfaces are clean and unharmed.
- Check that the gaskets are in good shape.
- Always assemble the Rack bundles according to below picture.
- It is not recommended to reuse gaskets, since these may have lost elastic properties due to service temperature of Rack bundle and aging.

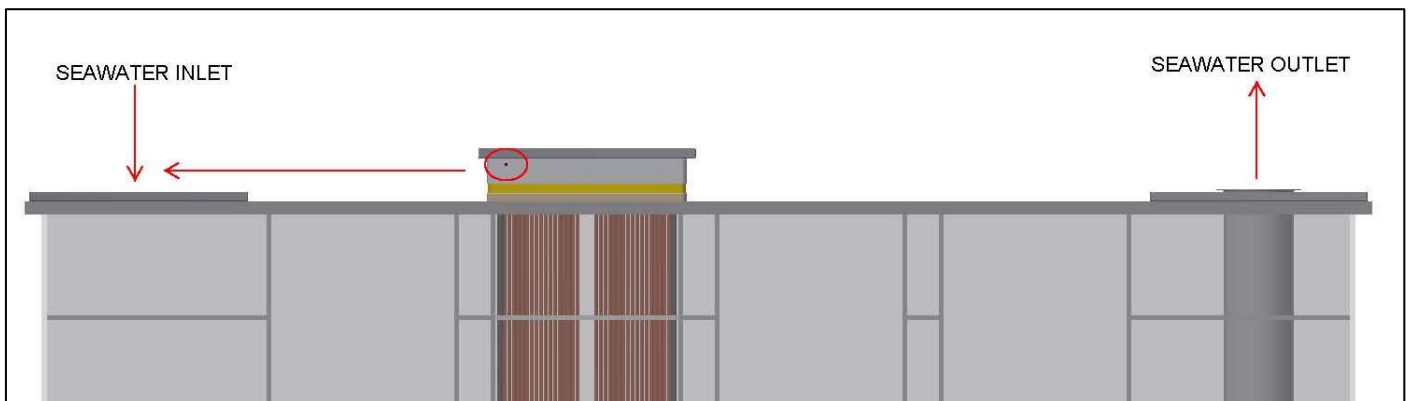

- Tighten the M16 nuts in a cross pattern with a torque of 120 Nm.
- Then tighten the M12 nuts in a cross pattern with a torque of 50 Nm.

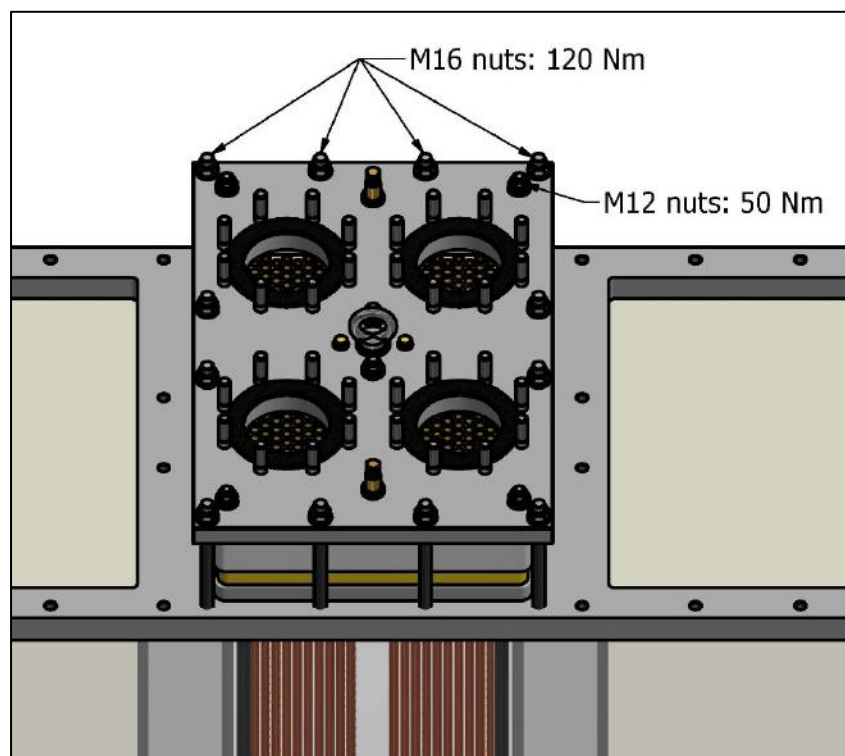

Note!

It is recommended to check the nuts after 3 months.

Cleaning procedure

Start by using high pressure washer cleaning the outside of the bundle. This can be done on location or dockside.

Flushing with chemical detergents for cleaning must be followed by thorough procedure for removal of detergents.

Make sure to use only chemicals compatible with material in Hydroniq Rack bundle. Mechanical brushing of tubes using metal brushes must be done with care in order not to harm tubes.

We recommend that you use a mild detergent without hydrochloric acid when cleaning the Rack bundle. We have used MULTI SCALE (20% Multi Scale and 80% water) with very good result on our Rack bundle.

Use this only if needed, because of tear and wear on the Cu/Ni pipes.

See example of a cleaning process with Multi Scale on the next two pages.

Hydroniq part no. Multi Scale:

20 litres: 8996

1000 litres: 8995

Cleaning process performed onboard or quayside with environmentally friendly liquids

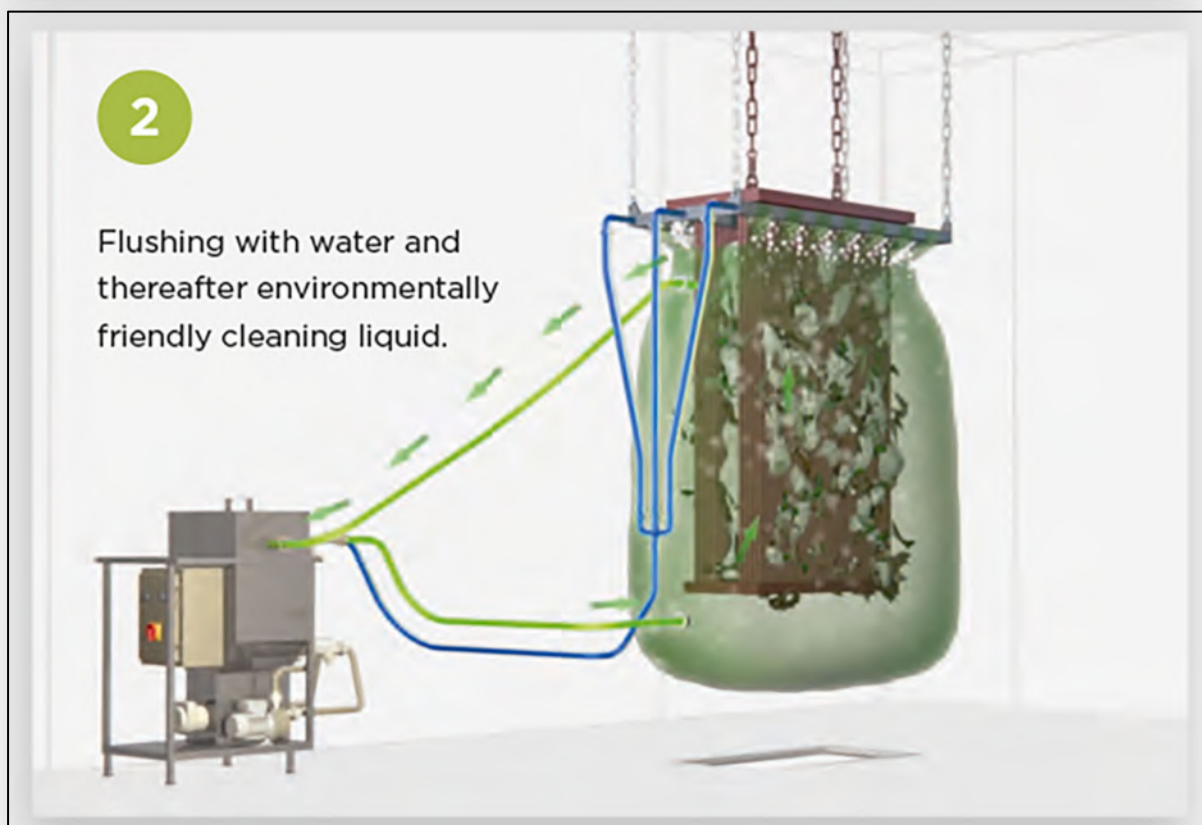
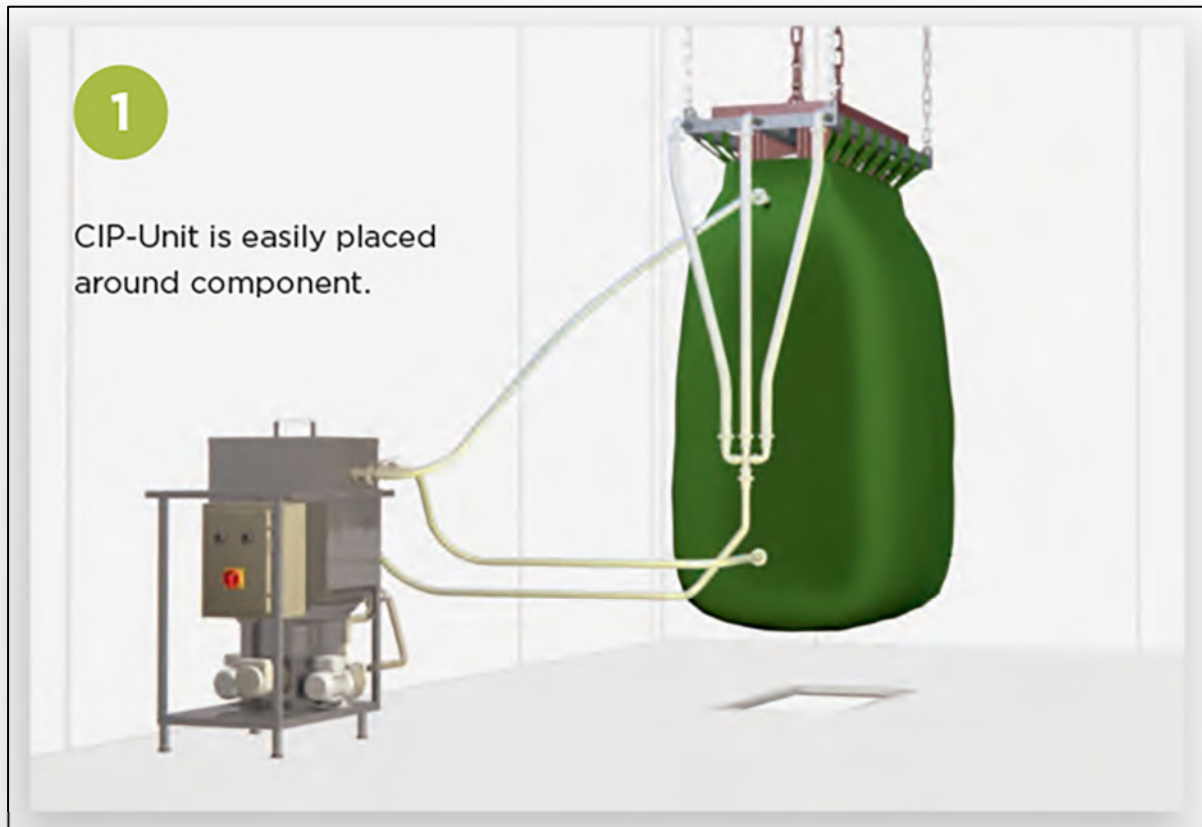

3

Highly efficient cleaning
without any damage
or danger to the
component.

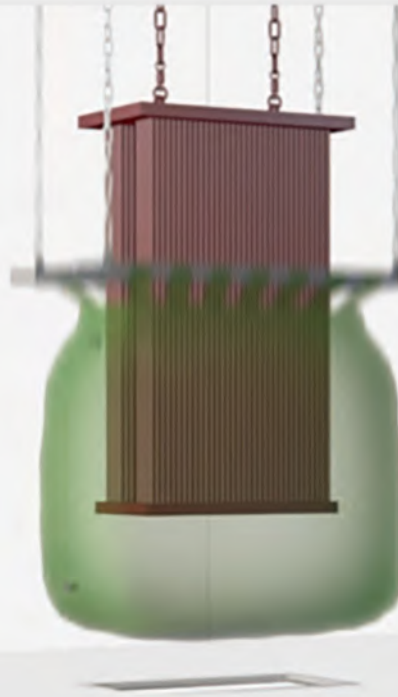

4

Clean component.



Torques

- | | |
|--|--------|
| 1. M12 nuts at the Rack bundle top plate: | 50 Nm |
| 2. M16 nuts for the zinc anode flanges: | 80 Nm |
| 3. M16 nuts at the Rack bundle top plate: | 120 Nm |
| 4. M16 nuts at the SW in-/ outlet plate: | 120 Nm |
| 5. M16 nuts for the FW pipe: | 120 Nm |
| 6. M16 nuts for the blind flanges: | 120 Nm |
| 7. M16 nuts at the spare top plate: | 120 Nm |
| 8. M16 nuts at the filter unit (option): | 120 Nm |
| 9. M16 nuts at the Protection unit (option): | 120 Nm |

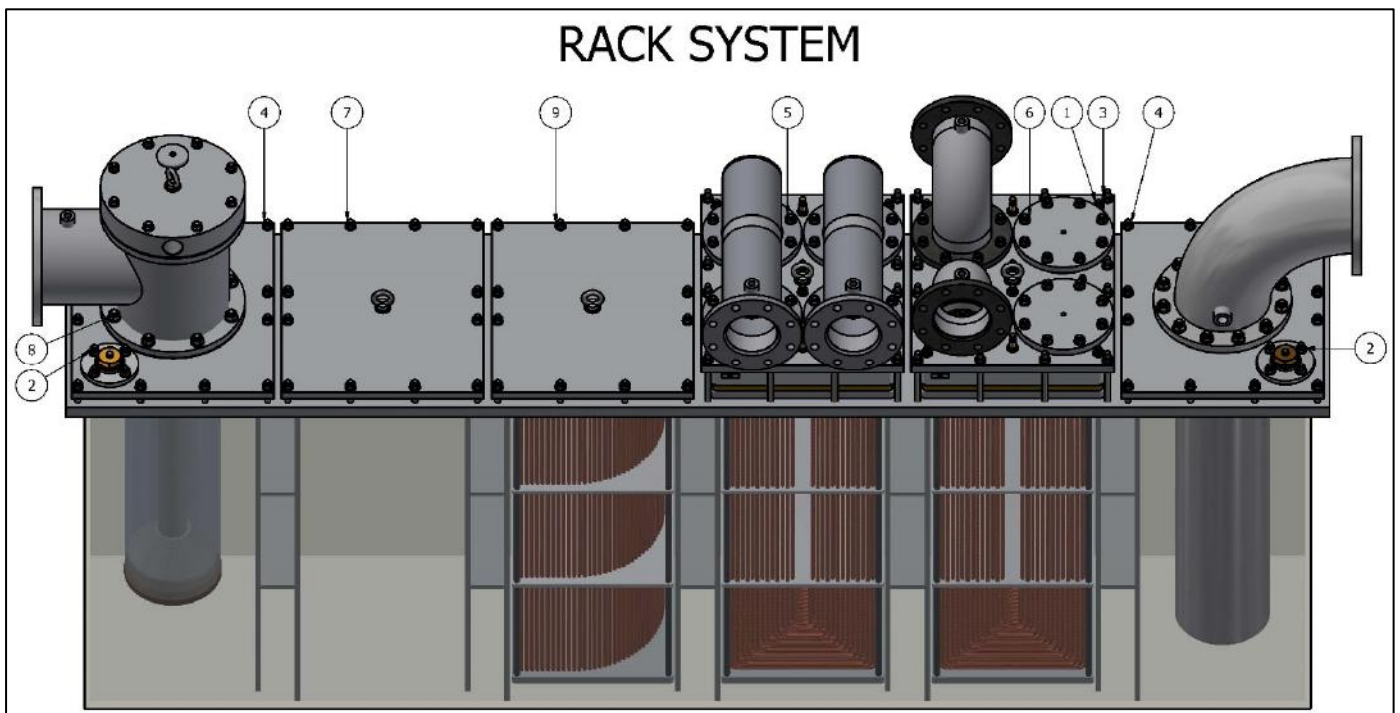

Note!

Ensure that the needed service space above all the compartments of the Rack system is maintained free of obstacles and other installations to secure the possibility of lifting the Rack bundles for inspection and service.

If installations above the Rack systems cannot be avoided, such installation must be made easily removable.

RECOMMENDED PLACEMENT OF LIFTING BEAM

(Example: Rack system - 600S x 1200)

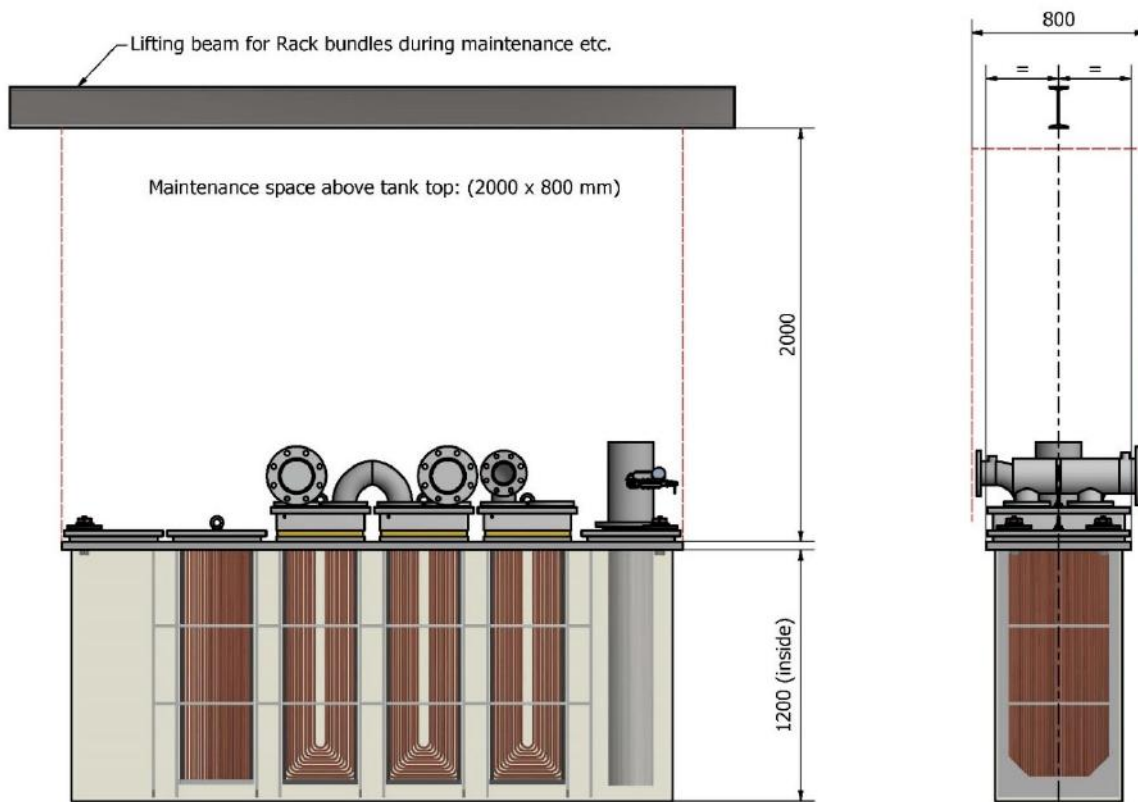









NOTE!

To find out the maintenance space above the Rack system, use the length inside the Rack case and add 800 mm.
800 mm = Approx. the crane and chain distance.

Recommended Spare parts – Rack 600S

| Part name | Sketch | Dimension (mm) | No. | Part no. |
|--|---|----------------|-----|----------|
| FW top plate |  | 690 x 580 | 0 | 8831S |
| Distribution frame |  | 634 x 524 | 1 | 8835S |
| Gasket FW (distribution frame) |  | 581 x 226 | 4 | 8843S |
| Bolt for distribution frame |  | M8 x 75 | 10 | 8646-01 |
| Gasket gland Tank top |  | 634 x 524 | 2 | 8839S |
| Gasket SW (gasket gland) |  | 603 x 499 | 4 | 8844S |
| Gasket for FW in-/outlet connections |  | 169 x 218 x 5 | 4 | 8856 |
| Zinc complete |  | 2" BSP | 0 | 8897 |
| Zinc anode |  | ø50 mm | 4 | 8898 |

| Part name | Sketch | Dimension (mm) | No. | Part no. |
|------------------------------|---|----------------|-----|-----------|
| Seal gasket for zinc |  | 2" BSP | 4 | 8899 |
| Ventilation kit |  | 1/2" BSP | 2 | 8666 |
| Ventilation hose |  | 1/4" BSP | | 8849-**** |
| Nipple for ventilation hoses |  | 1/4" BSP | 0 | 8849-05 |
| Cap nut with gasket |  | 1/4" BSP | 0 | 8849-06 |
| Ventilation bolt |  | M12 | 2 | 8656 |
| Gasket for ventilation bolt |  | 6 x 11 x 1 | 2 | 3925 |
| Nut for ventilation bolt |  | 1/4" BSP/ M12 | 2 | 8660 |

**** = Length of the flexible hose(s)

| Part name | Sketch | Dimension (mm) | No. | Part no. |
|---------------------------|---|---|------------------|------------------------------|
| Guide for M12 bolts |  | Ø36/ Ø30 | 8 | 8845 |
| M12 bolt on top of bundle |  | M12 x 135 | 6 | 8644-01 |
| Nut for M12 bolts |  | M12 | 6 | 8642 |
| Washer for M12 bolt |  | Ø13 | 6 | 8649 |
| Plug FW top plate |  | 1/4" BSP | 2 | 4294 |
| Bonded seal |  | 1/4" | 2 | 8946 |
| Brass plug |  | Ø12,7 mm | 20 | 4686 |
| Rack element |  | 600S x 800 600S x 1000 600S x 1200 600S x 1500 | 0 0 0 0 | 890S 892S 893S 881S |

FAULT FINDING AND TROUBLE SHOOTING

Rack insulation guard

| Fault | Check list |
|--------------------------|---|
| Faulty Insulation System | Check that the parameters are correctly set for the numbers of bundles. (See chapter "Operation – Insulation guard" for settings) |
| | Check all cables, and that each Rack bundle is in generally good condition |
| | Open the Rack system and inspect the seawater side |
| | Check the sacrificing anodes |
| | Check each stud bolt between top plate and Rack bundle for dirt |
| | Check for dirt between the Rack bundles and Rack case top plate |

Ventilation kit

| Fault | Check list |
|--|--|
| Safety valve blows during emptying the Rack case | Check if flexible hoses are blocked internally or externally |
| | Reduce air pressure into the 3-way valve |
| Safety valve leakage during operation | Change the ventilation kit |

Cooling

| Fault | Check list |
|------------------------------------|---|
| Low water flow in SW system | Check filters, pumps and valves |
| Dirty protection unit/ filter unit | Clean protection unit/ filter unit |
| Wrongly installed element | Check that the elements are mounted correctly. The small marking on the distribution frame shall always point towards seawater inlet. (See chapter "Rack bundle – Assembly direction"). |
| Dirty element | Clean the element |
| Low water flow in FW system | Check for obstructions on top of the Rack bundle |

Leakages

| Fault | Check list |
|--|--|
| Loosing FW | Check if Rack system is leaking by closing the in- / outlet valves and see if you stop losing FW |
| | Check which Rack bundle is leaking if possible, by closing the in- / outlet valves and see if you stop losing FW |
| | Check for leakages around the Rack system |
| | Pressure test the Rack system. (See chapter "How to check internal leakage in Rack cooler" on next page) |
| Increased salinity in FW | (See chapter "How to check internal leakage in Rack cooler" on next page) |
| SW leakage external | Locate the leakage by visual inspection |
| Leakage around the gasket gland against the tank top | Check for loose items |
| | Check the torque of the nuts around the Rack bundle |
| | Lift the Rack bundle to check the gaskets, gasket gland and gasket surfaces |
| Leakage around the ventilation kit | Check the kit for corrosion |
| | Check for loose part on the kit |
| Leakage around the ventilation bolt(s) | Check the gasket (part no. 3925) inside the ventilation nut (part no. 8660) |
| | If the ventilation bolt is loose, use thread sealant |

How to check internal leakage in Rack bundle

- Close SW inlet.
- Open the 3-way air valve at the ventilation kit and insert air into the Rack case. SW outlet must be open. Do not exceed 2 bar. You will now empty the Rack case for SW.

Normal running

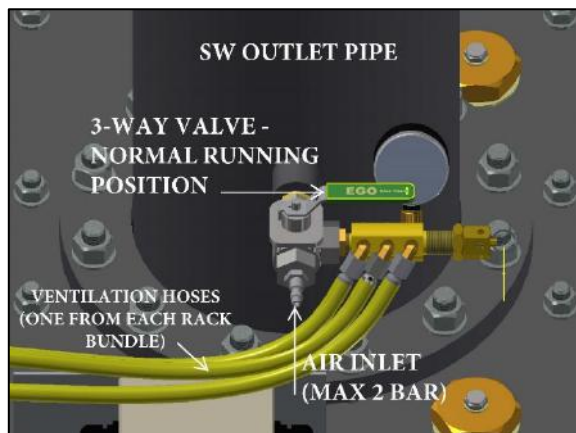

Cleaning/ Empty the Rack case for SW

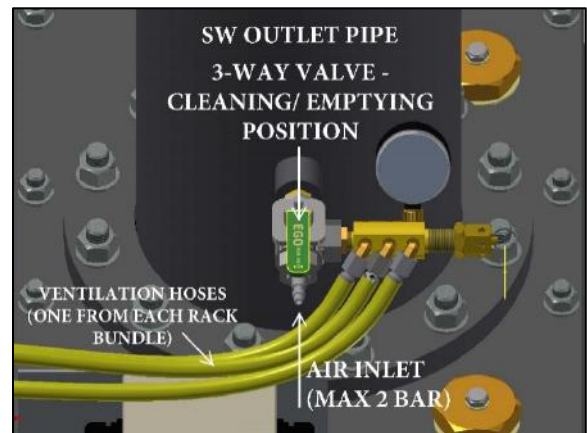

- When Rack case is empty, close SW outlet valve and the air inlet valve on the ventilation kit.
- Close FW valves inlet and outlet.
- If you want to avoid any spill of FW/ glycol, use the FW evacuation kit (part no. 8905-P) to evacuate the FW/ glycol down to the top of the top plate. (See how to connect this kit in the User manual).
- Remove all the FW piping/ Blind flanges.
- Open the air inlet valve again. This is to increase the pressure inside the Rack case (Not more than 2 Bar)
- If there are broken internal pipes, bubbles will appear, and you will find the leakage.



- This can be repaired with a plug, Hydroniq part no. 4686.
- Reduce pressure inside the Rack case by opening the SW outlet valve, or by disconnect the air inlet hose on the ventilation kit.
- To evacuate all air inside the Rack case, leave 3-way valve open (at cleaning/ emptying position) until there comes water out of the air inlet hose connection.
- Turn the 3-way valve back to normal running position again.
- The Rack system is now ventilated, and you can open all valves again.

How to plug a broken tube on a Rack bundle

- Locate the leakage
- Find the brass plug (See inside the Insulation guard)

Brass plug (Part no. 4686)



Plugs inside Insulation guard



- Carefully hit the plug with a hammer into the tube. Remember this is a U-tube cooler, so you need also to plug the other side of the tube. Do not use force.

Do it like this:



Hydroniq RACK cooler is a module-based system, built up by several U-bundles. Since it can be difficult to change a broken tube in a U-bundle, Hydroniq Coolers always adds an extra 1% cooling surface in the capacity calculations, in case of broken tubes during production, installation or start-up. The extra margin in the calculation, and extra tubes installed, will allow for plugging several tubes in service. With up to 1% plugged tubes in a RACK-bundle, Hydroniq Coolers guarantees a 100% cooling capacity as designed and according to design criteria, and therefore consider the bundle as a full worthy product.

HOW TO ORDER SPARE PARTS:

See the chapter “How to order spare parts” at the end of this manual.

PART LIST & ILLUSTRATIONS

Top plate for seawater inlet

Hydroniq Rack coolers have a seawater inlet top plate that can be fitted to different sizes and standards.

As standard there are two DN50 flanges with 2" BSP threads that can be used for Zinc anodes or for extra connections as clean in place (CIP), cooling in dry-dock etc.

Use 120 Nm torque for the M16 nuts (Part No. 9213).

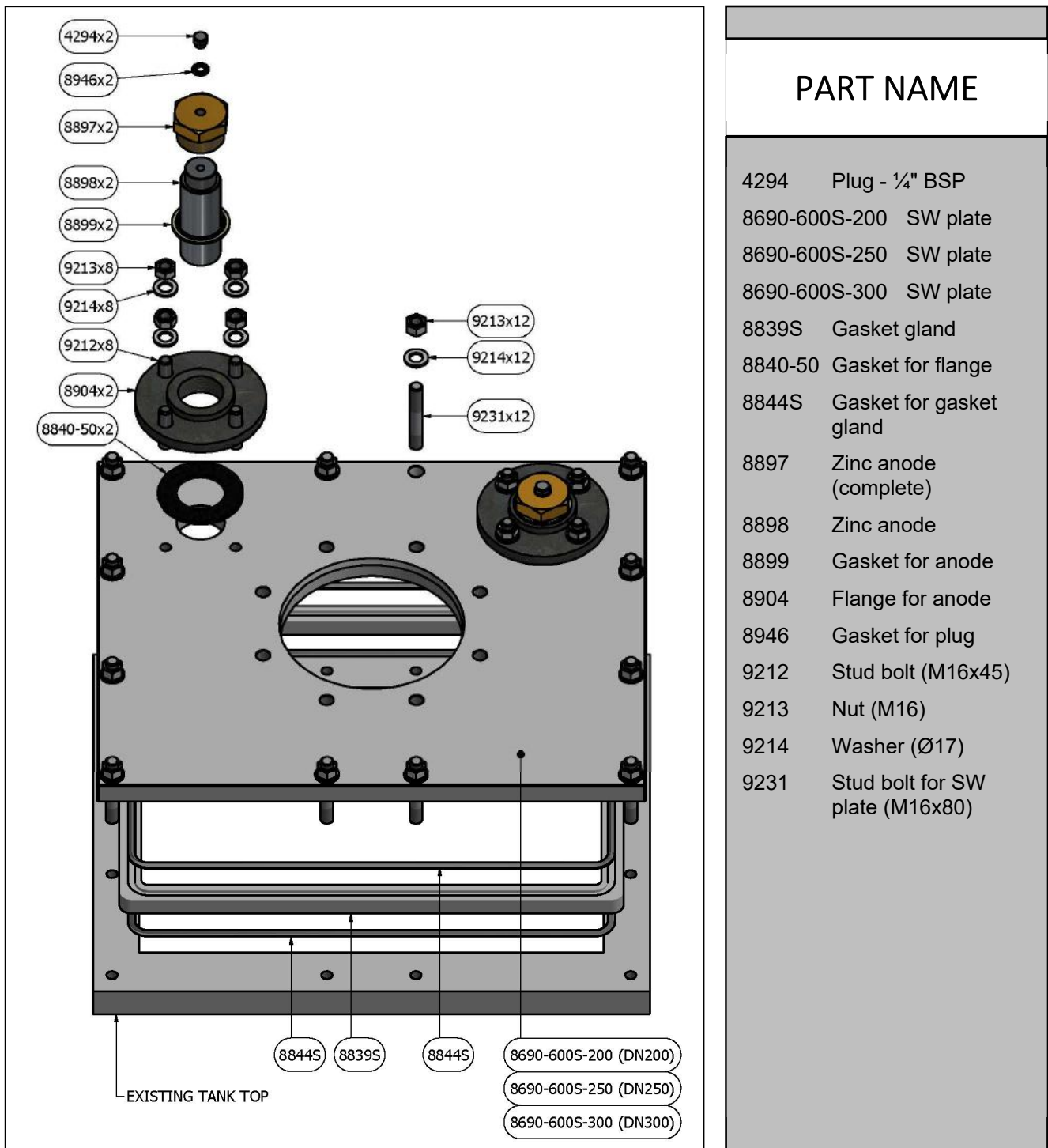

Top plate for seawater outlet

Hydroniq Rack coolers have a seawater outlet top plate that can be fitted to different sizes and standards.

A discharge pipe makes sure that all particles follow the water out.

As standard there are two DN50 flanges with 2" BSP threads that can be used for Zink anodes or for extra connections as back-flushing, etc.

Use 120 Nm torque for the M16 nuts (9213).

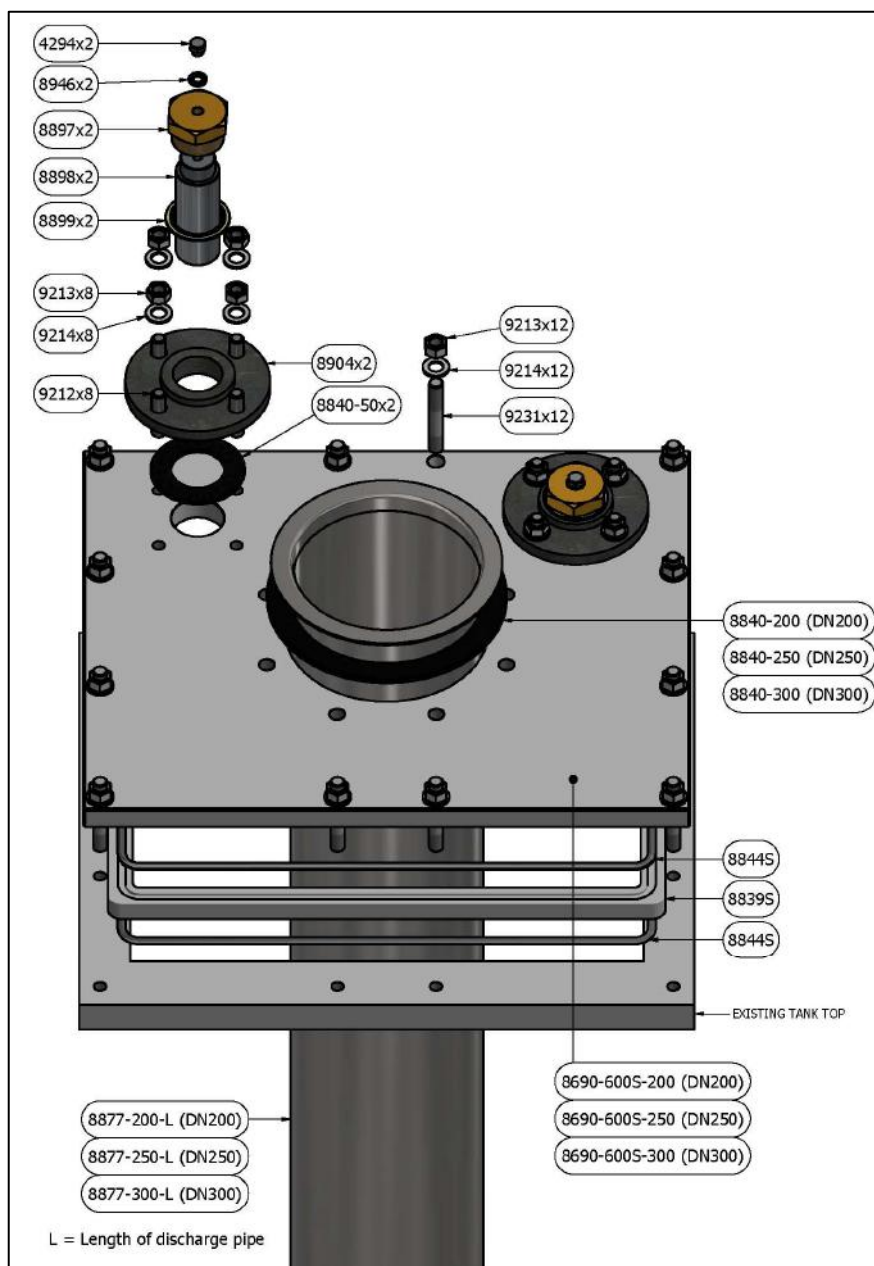

PART NAME

| | |
|---------------|---------------------------------|
| 4294 | Plug (¼" BSP) |
| 8690-600S-200 | SW plate |
| 8690-600S-250 | SW plate |
| 8690-600S-300 | SW plate |
| 8839S | Gasket gland |
| 8840-50 | Gasket for flange |
| 8840-200 | Gasket for discharge pipe |
| 8840-250 | Gasket for discharge pipe |
| 8840-300 | Gasket for discharge pipe |
| 8844S | Gasket for gasket gland |
| 8877-200-L | Discharge pipe |
| 8877-250-L | Discharge pipe |
| 8877-300-L | Discharge pipe |
| 8897 | Zinc anode (complete) |
| 8898 | Zinc anode |
| 8899 | Gasket for anode |
| 8904 | Flange for anode |
| 8946 | Gasket for plug |
| 9212 | Stud bolt (M16x45) |
| 9213 | Nut (M16) |
| 9214 | Washer (Ø17) |
| 9231 | Stud bolt for SW plate (M16x80) |

Blind plate/ Top plate for Protection unit

When Hydroniq coolers are installed, it normally has one blind plate that later can be used for easy access to the system, or to have extra space to install extra elements if needed to increase capacity.

This blind plate/ protection unit top plate has one lifting lug for easy handling (delivered by Hydroniq).

The protection unit (mounted by Hydroniq before delivery) is located below this blind/ protection unit top plate.

Use 120 Nm torque for the M16 nuts (9213).

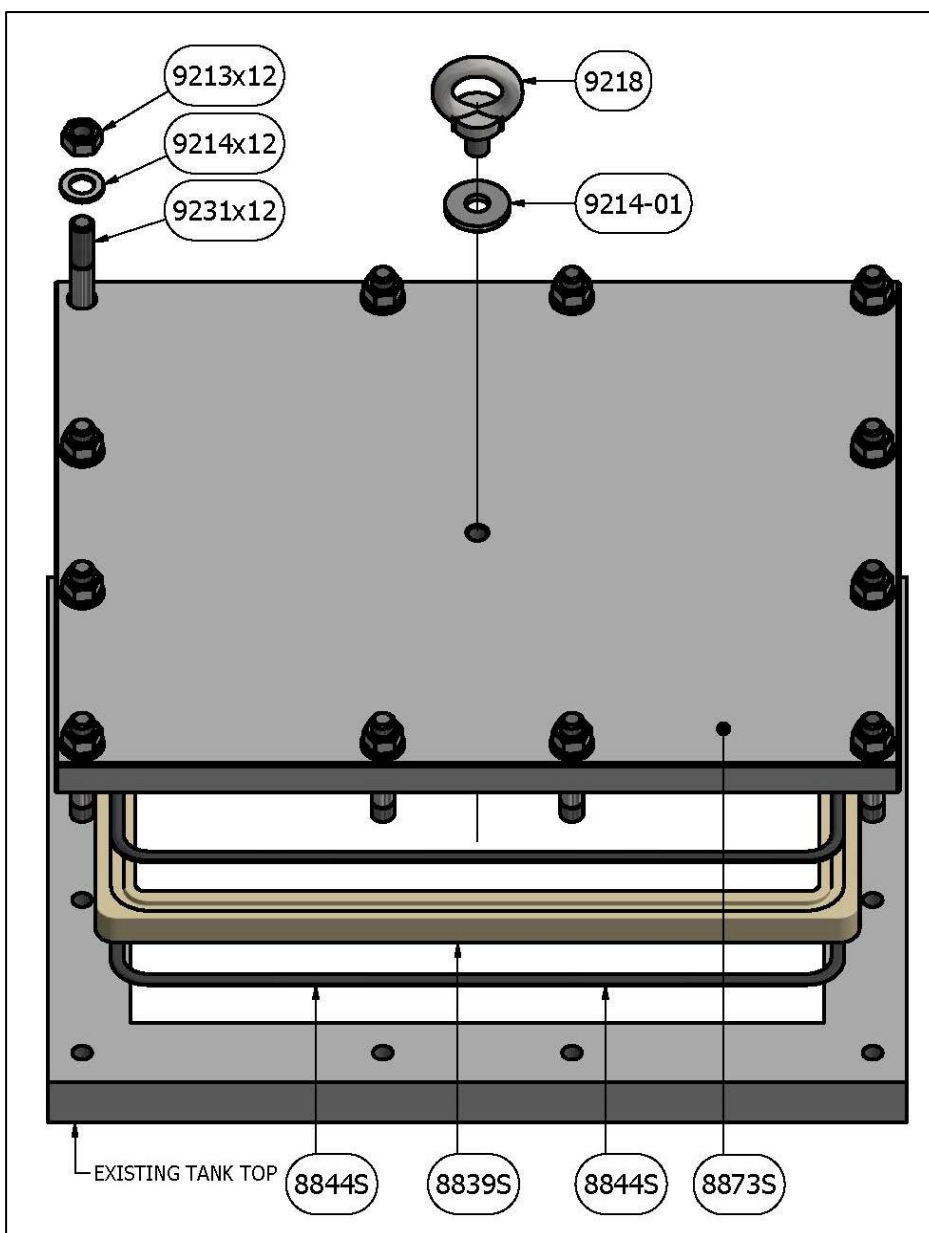

PART NAME

| | |
|---------|---------------------------------|
| 8839S | Gasket gland |
| 8844S | Gasket for gasket gland |
| 8873S | Top plate for Protection unit |
| 9213 | Nut (M16) |
| 9214 | Washer (Ø17) |
| 9214-01 | Washer for lifting eye |
| 9218 | Lifting eye |
| 9231 | Stud bolt for SW plate (M16x80) |

Top plate for Rack bundle

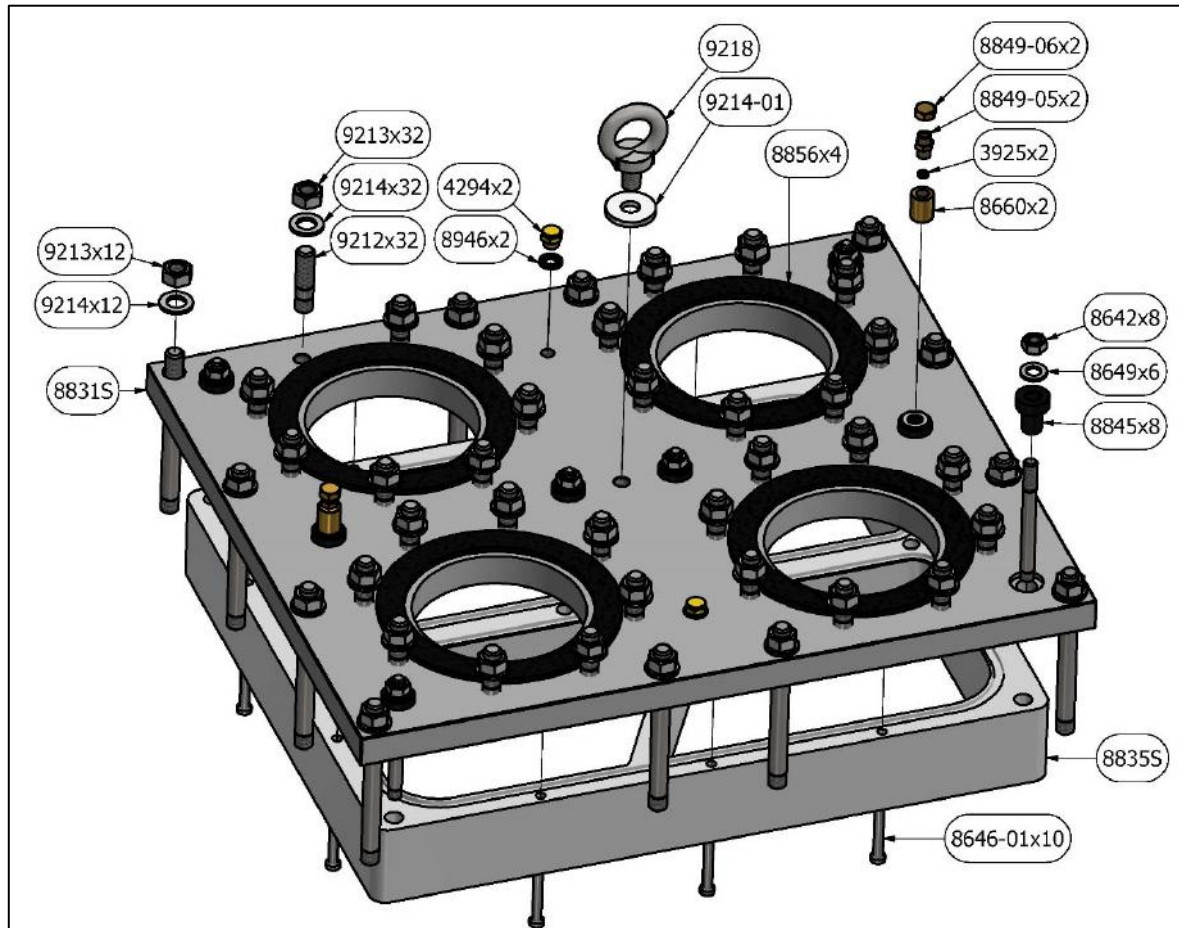

PART NAME

| | |
|---------|--|
| 3925 | Copper gasket for vent. bolt |
| 4237 | Nut (M12) |
| 4294 | Plug (1/4" BSP) |
| 8644-01 | Stud bolt for Rack element (M12x135) |
| 8645 | Stud bolt for Rack element (M16x200) |
| 8646-01 | Unbraco screw for distribution frame (M8x75) |
| 8649 | Washer (Ø13) |
| 8656 | Ventilation bolt (M12) |
| 8660 | Nut for ventilation bolt (M12) |
| 8831S | Top plate – FW |

PART NAME

| | |
|---------|---|
| 8835S | Distribution frame |
| 8845 | Guide for M12 bolts |
| 8849-05 | Nipple (1/4" BSP) |
| 8849-06 | Nut with gasket (1/4" BSP) |
| 8856 | Gasket for FW in-/ outlet conn. (DN150) |
| 8946 | Gasket for plug |
| 9212 | Stud bolt (M16x45) |
| 9213 | Nut (M16) |
| 9214 | Washer (Ø17) |
| 9214-01 | Washer for lifting eye (Ø17) |
| 9218 | Lifting eye (M16) |

Note!

When you loosen the M16 nuts around the Rack bundle (part no. 9213), you will lift up the whole Rack bundle.

When you loosen the M16 nuts around the Rack bundle (part no. 9213), the M12 nuts (part no. 8642) and the two ventilation “nuts” (part no. 8660) on the Rack bundle top plate, you will lift up only the FW top plate along with the distribution frame.

The Rack bundle will stay in place. This because the distribution frame is connected to the FW top plate with M8 unbraco screws (part no. 8646-01).

If you are going to change/ replace the gaskets (part no. 8843S) on this distribution frame, you must remove the unbraco screws.

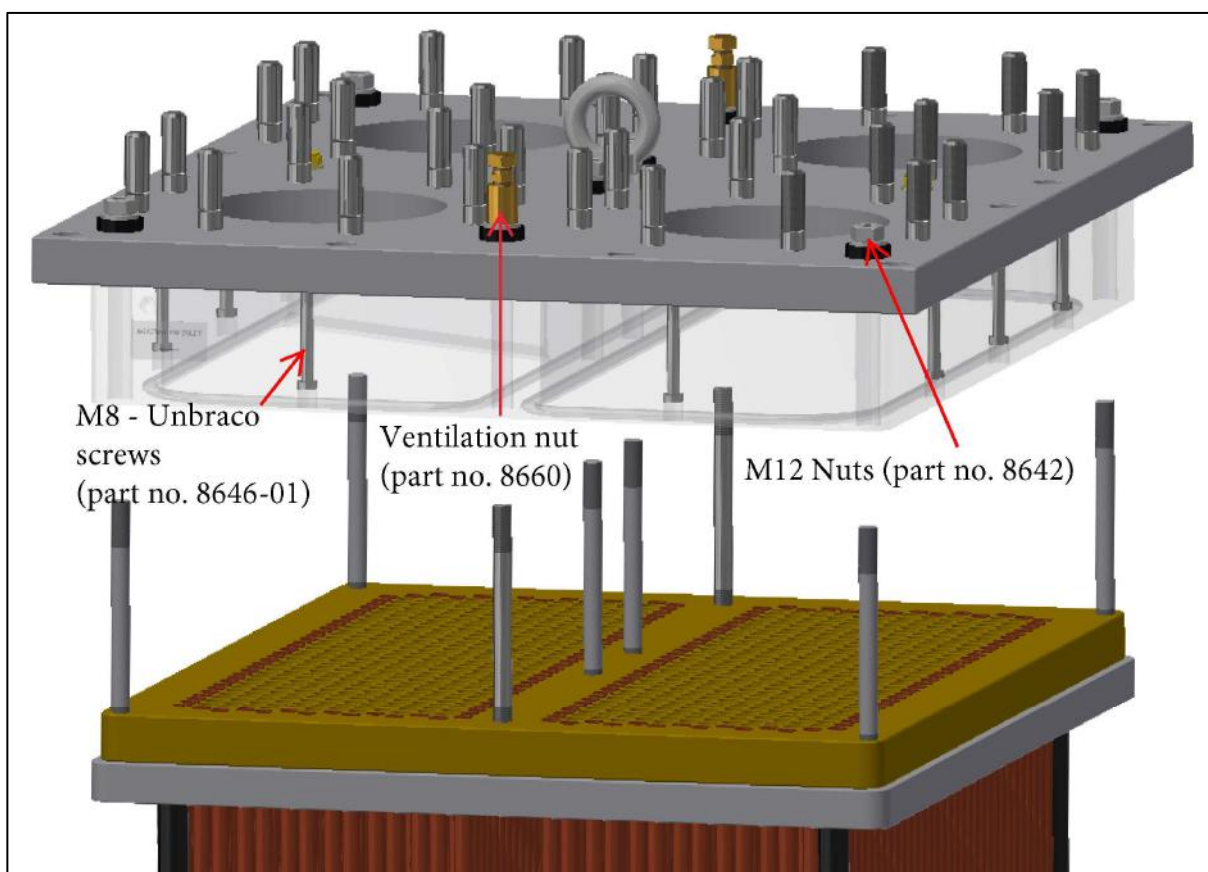

Rack bundle

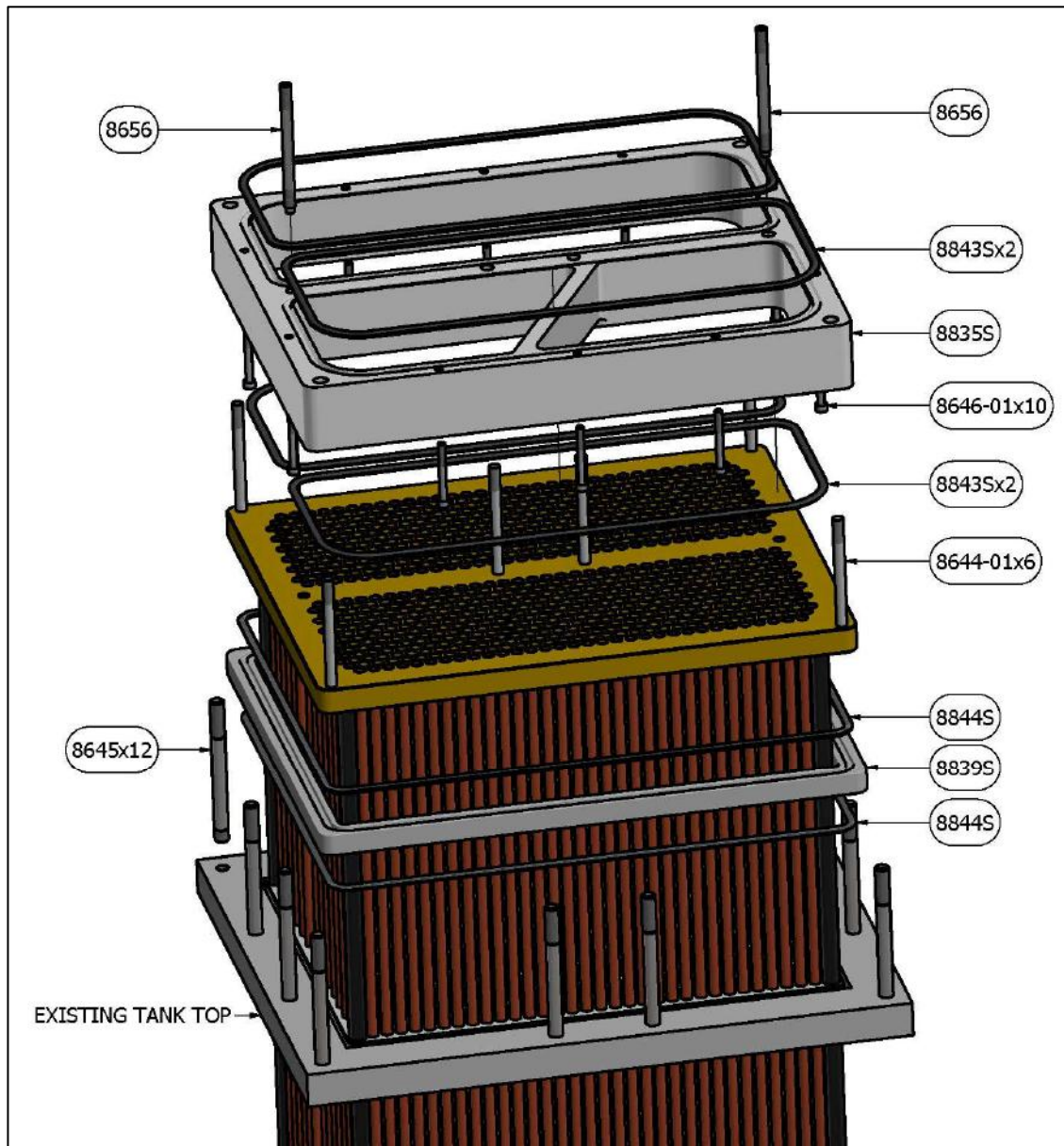

PART NAME

| | |
|---------|--|
| 8644-01 | Stud bolt for Rack element (M12x135) |
| 8645 | Stud bolt for Rack element (M16x200) |
| 8646-01 | Unbraco screw for distribution frame (M8x75) |
| 8656 | Ventilation bolt (M12) |

PART NAME

| | |
|-------|-------------------------------|
| 8835S | Distribution frame |
| 8839S | Gasket gland |
| 8843S | Gasket for distribution frame |
| 8844S | Gasket for gasket gland |

Ventilation kit and hoses

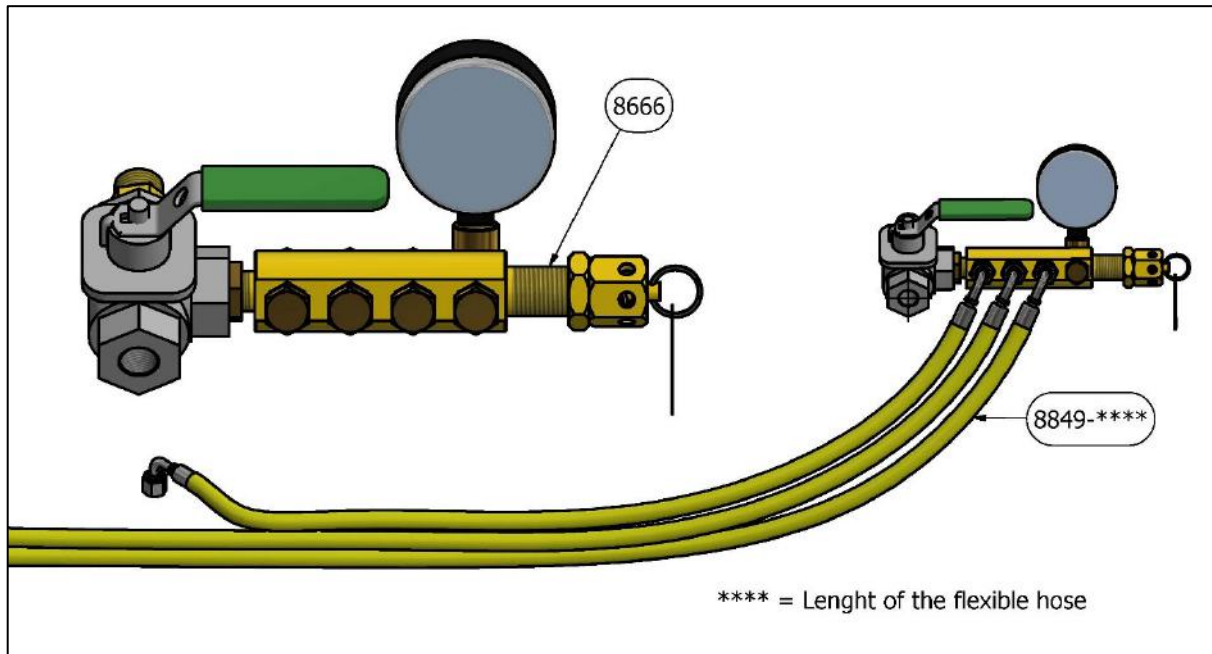

| PART NAME | |
|-----------|------------------|
| 8666 | Ventilation kit |
| 8849-**** | Flexible hose(s) |

Protection unit (Option)

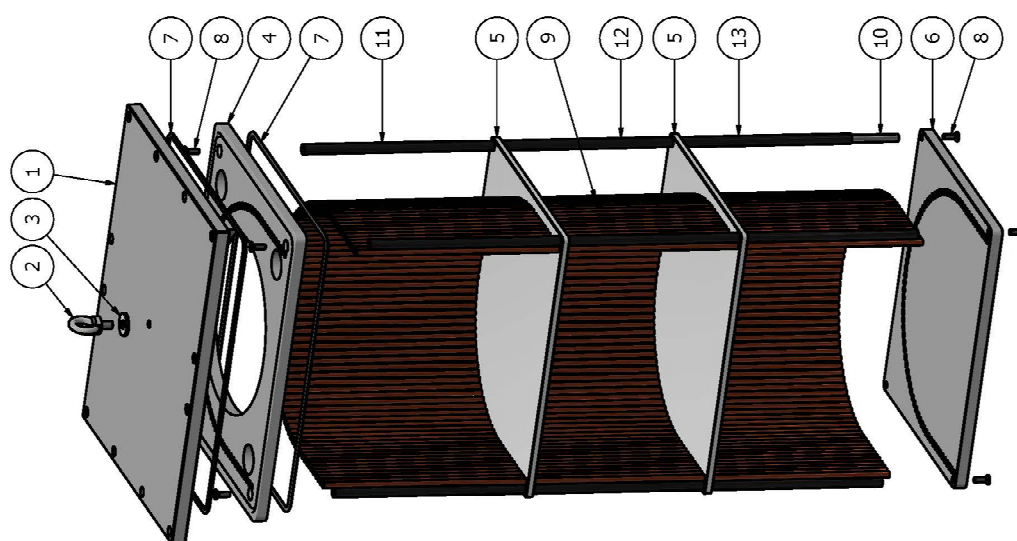

When Hydroniq Rack coolers are installed, it normally has one or more blind plates that later can be used for easy access to the system or to have extra space to install extra elements if needed to increase capacity.
The blind plate has one lifting lug for easy handling.

The protection unit (mounted by Hydroniq before delivery) is located below this blind plate.

Use 120 Nm torque for the M16 nuts (9213).

| Pos. No. | PART NO. - TABLE | |
|----------|------------------|---------------|
| | L=800 mm | L=1000 mm |
| 10 | 8910-608S-750 | 8910-610S-950 |
| 11 | 8688-240 | 8688-310 |
| 12 | 8688-240 | 8688-305 |
| 13 | 8688-240 | 8688-305 |

| Pos. No. | Description | Qty | Part No. | Material |
|----------|--------------------------------|-----|-----------|----------|
| 13 | Distance tube | 4 | See table | HYDRONIQ |
| 12 | Distance tube | 4 | See table | HYDRONIQ |
| 11 | Distance tube | 4 | See table | HYDRONIQ |
| 10 | Stiffener | 4 | See table | HYDRONIQ |
| 9 | Tubes - $\phi 12,7$ mm - Cu/Ni | 76 | | HYDRONIQ |
| 8 | Screw - M10 x 30 | 8 | 9239 | HYDRONIQ |
| 7 | O-ring gasket gland - 600S | 2 | 8844S | HYDRONIQ |
| 6 | Bottom plate | 1 | 8804-600S | HYDRONIQ |
| 5 | Baffle | 2 | 8803-600S | HYDRONIQ |
| 4 | Gasket gland | 4 | 8802-600S | HYDRONIQ |
| 3 | Washer for lifting eye | 1 | 9214-01 | HYDRONIQ |
| 2 | Lifting Eyebolt - M16 | 1 | 9218 | HYDRONIQ |
| 1 | Blind plate - 600S | 1 | 8873S | YARD |

| ITEM | QTY | DESCRIPTION | PART NUMBER | SUPPLY |
|-----------------|-----|-------------|-------------|--------|
| RACK | | | | |
| Protection unit | | | | |
| 600S | | | | |
| 1-Pass | | | | |

Hydroniq logo and company information: Hydroniq Coolers AS, Fredøys Ellingsøy, Norway. Drawing no. 8801-600S-1-P.

Filter unit (Option)

Note!
 3* Std. length is 1000 mm
 Part no. for 800 mm length is 8741-800
 7* Part no. for 800 mm length filter is 8731-800-ny
 10* Part no. for 800 mm length filter is 8732-800
 11* Part no. for 800 mm length filter is 8735-800

| REV | DESCRIPTION | REVISION HISTORY | DATE |
|-----|--|------------------|------------|
| A | Change floater (pos. 4) | | 01.06.2017 |
| B | Added a o-ring on top of manual handle | | 27.07.2018 |
| C | Change material from Brass to AISI 316 L | | 21.09.2018 |

| ITEM | QTY | DESCRIPTION | PART NUMBER | MATERIAL |
|------|-----|------------------------------------|-------------|---------------|
| 25 | 1 | Silicone gasket for filter | 8737-01 | Silicone |
| 24 | 1 | O-ring inside manual handle - Ø8x2 | 8749 | NBR70 |
| 23 | 1 | Washer for lifting eye | 9214-01 | AISI 316 L |
| 22 | 1 | Locking nut - M16 | 9240 | A4 |
| 21 | 3 | Hex Nut - M16 | 4261 | A4 |
| 20 | 1 | Washer, big - M16 | 9214-03 | A4 |
| 19 | 8 | Stud bolt - M16 x 100 | 9221 | A4 |
| 18 | 9 | Washer - M16 | 4266 | A4 |
| 17 | 8 | Hex Nut - M16 | 4260 | A4 |
| 16 | 1 | Sealing ring - 30 x 7,5 mm | 8717 | Rubber |
| 15 | 1 | Unbraco screw - M8 x 40 | 9220 | A4 |
| 14 | 2 | O-ring for manual handle | 8736 | NBR70 |
| 13 | 1 | O-ring for stiffener | 8744 | NBR70 |
| 12 | 1 | Lifting eye - M16 | 8958 | EZ |
| 11 | 1 | Stiffener for manual handle - Ø20 | 8735-02* | AISI 316 L |
| 10 | 1 | Stiffener for filter unit - Ø16 | 8732-08* | AISI 316 L |
| 9 | 1 | Locking flange - M16 | 8719 | A4/AISI 316 L |
| 8 | 1 | Manual handle | 8734 | PPH |
| 7 | 1 | Pipe for filter unit | 8731-02* | Polyuretan |
| 6 | 1 | Bottom plate 2 - Filter unit | 8733-02 | AISI 316 L |
| 5 | 1 | Bottom plate 1 - Filter unit | 8733-01 | Polyuretan |
| 4 | 1 | Floater for SW filter | 8738-08 | Polyuretan |
| 3 | 1 | Filter | 8741-1000* | AISI 316 L |
| 2 | 1 | Amplifier for filter unit | 8730 | PPH |
| 1 | 2 | Gasket for amplifier | 8740 | Neoprene |

***For correct part no:
See below**

- 8950-3015* (DN150/ DN150)
- 8950-3020* (DN300/ DN200)
- 8950-3025* (DN300/ DN250)

| Scale | 1:1.2 |
|----------|------------|
| Drawn | 20.12.2016 |
| Approved | |

| Register | Revisiões | No. | Date |
|----------|-----------|-----|------|
| A | | | |
| B | | | |
| C | | | |
| D | | | |
| E | | | |

Hydroniq
 Hydroniq Coolers AS
 A-022, Eilivass, Norway

Working drawing
 SW filter unit
 Version 2

Drawing no. **8950-3025-P**

HOW TO ORDER SPARE PARTS

When ordering please inform:

1. Rack Cooler type.
2. Order no.
3. Part no.
4. Quantity.

1. The Rack cooler type and order no. can be found on the frontpage of the Installation manual
2. Part no. you will find in the section “Part list and Illustrations” of this User manual.

Note!

HYDRONIQ disclaims all liability for damage due to the use of non-genuine replacement parts.

Orders for replacement parts should be sent to:

Hydroniq Coolers AS
Ellingsøyvegen 740
N-6057 Ellingsøy
Norway

Tel: + 47 70 10 42 00

E-mail: info@hydroniq.no

ADDITIONAL INFORMATION

Please refer to the Hydroniq Installation manual for additional information of the design and installation of the Rack cooler.

