

MECH-ROLLER

Mech-Roller 24V motorized rollers are built-to-last. Equipped with an all-metal drivetrain with multiple motor-reducer combinations, precision bearings, and zinc plated tube, Mech-Roller is the solid solution for your 24V MDR conveyor.

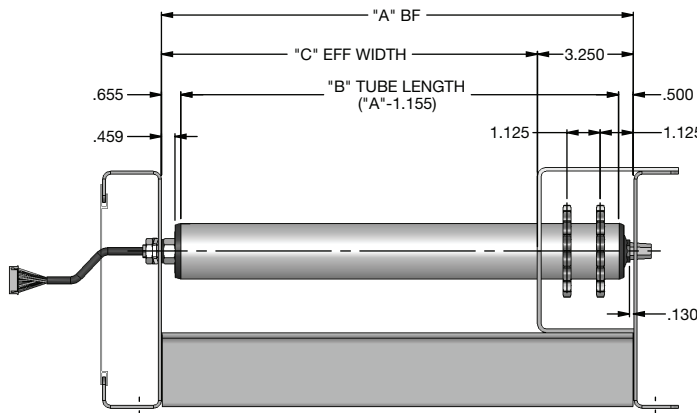

MODEL SP19 *Sprocketed, 1.9 diameter*



Dimensions (inches)				
	A Between Frame	B Tube Length	C Sprocket 1	D Sprocket 2
Range	14 to 39	12.8 to 37.8	2 1/4 min	1 1/8 min
Standard	1/16 incr.	1/16 incr.	2 1/4	1 1/8

Roller Specifications	
Tube	1.9 diameter x 16 gauge, zinc plated
Motor	24V Brushless DC
Reducer	Planetary gear reducer
Bearings	ABEC precision, sealed
Motor Side Axle	7/16 threaded hex axle (11/16 for square roller)
Grooved Side Axle	7/16 tapered hex axle (11/16 for square roller)
Sprockets	(2) 40A18 sprockets

Motor	No Load Linear Speed (FPM)	Reducer	Rated Torque (in-lbs.)	Startling Torque (in-lbs.)	Current (Amps)	Motor Lead	Connector	Driver Card (Sold Sep.)
22 Watt	5 to 20	49:1	46	106	0.5 to 2.0	12" long*	Molex	N24-22W ZPA Transportation Brake
	14 to 60	25:1	24	54				
	24 to 100	11.56:1	10	24				
	55 to 238	5:1	4	11				
35 Watt	13 to 44	49:1	40	150	0.5 to 2.8	12" long*	JST	N24-35W ZPA Transportation
	26 to 88	25:1	19	82				
	43 to 146	11.56:1	12	49				
	94 to 328	5:1	4	22				

*For longer lead length, use extension cable (sold separately)
Maximum of 20 slaved rollers per Mech-Roller recommended

Utilize the N24-22W (22 watt motor) and the N24-35W (35 watt motor) driver cards with Mech-Roller. Each card functions for Zero Pressure Accumulation and Transportation applications, and includes onboard I/O, DIP switches, and speed potentiometer allow adjustment of parameters. Additional features available using our free software download.



advanced equipment
CO. INC.

www.aecmd.com - 800-648-2600