

FCV-620 Series

High Speed 5-Axis Machining Center



AWEA MECHANTRONIC CO., LTD.

HEADQUARTERS

629, Suezhetou Section, Kwanpu Rd., Wenshan Li,
Hsinpu, Hsinchu 305, Taiwan
TEL : +886-3-588-5191
FAX : +886-3-588-5194
Website : www.awea.com

CENTRAL TAIWAN SCIENCE PARK BRANCH

15, Keyuan 2nd Rd., Central Taiwan Science Park,
Taichung 407, Taiwan
TEL : +886-4-2462-9698
FAX : +886-4-2462-8002
E-mail : sales@awea.com

ISO 9001



ISO 14001

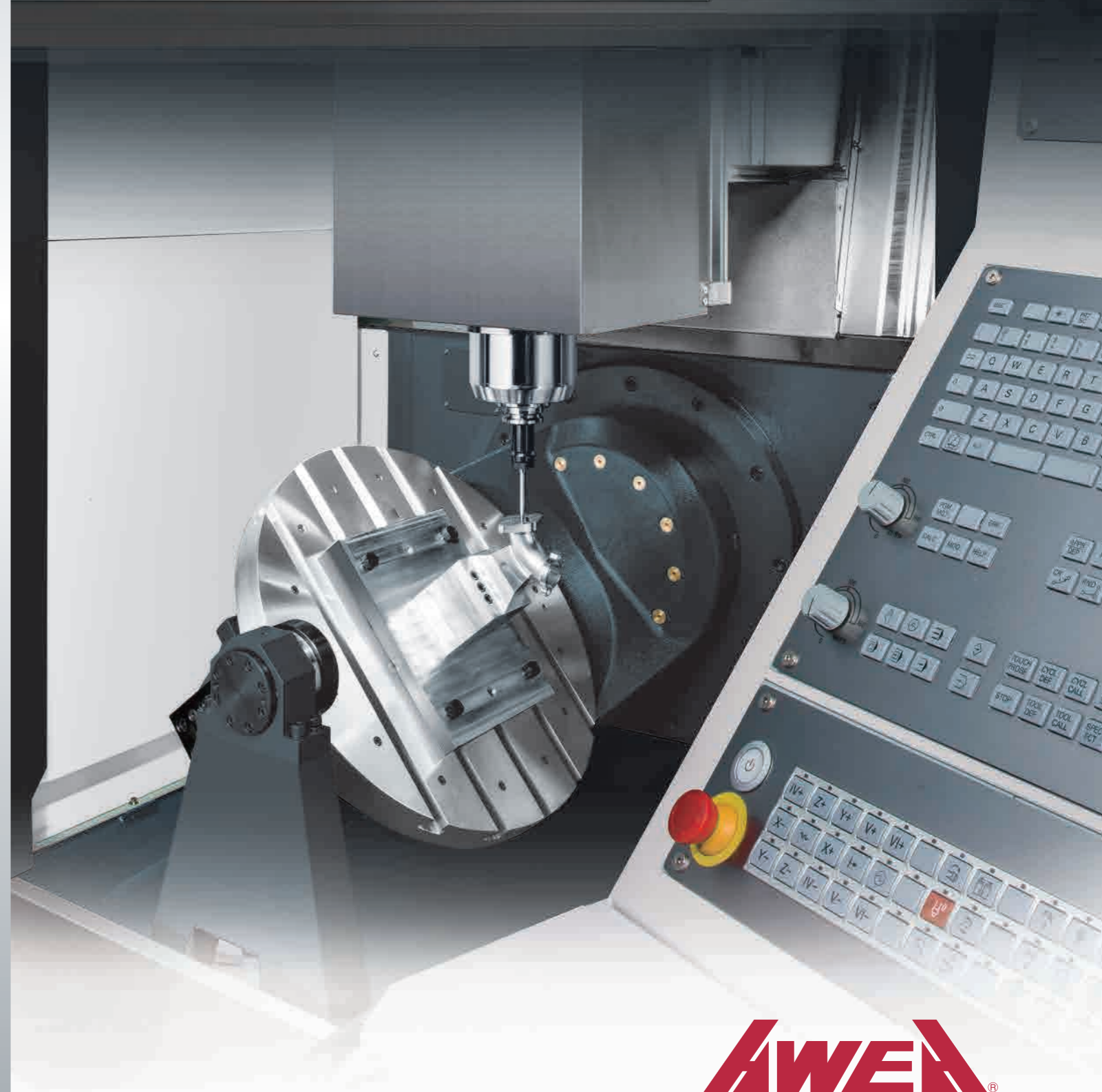

FCV-620 Series

High Speed 5-Axis Machining Center

Derived from AWEA's advanced R&D technology and high quality components, FCV-620 5-axis machining center offers high speed, high accuracy, easy operation and many other superior capabilities.

FCV-620 offers the best cost performance ratio than any other same class 5-axis machining centers in the field.

- Outstanding 5-axis simultaneous machining ability can finish complicated parts in a single setup which especially suits automobile, aerospace, medical and other industries that demand high accuracy.
- High performance B / C axes rotary working table. Table load capacity is up to 300 kg (0°~45°). B-axis swiveling range is -50°~ +110°.
- Depending on machining requirements, FCV -620 provides 12,000 / 15,000 rpm direct-driven spindle or 16,000 / 20,000 rpm high speed built-in spindle for option.

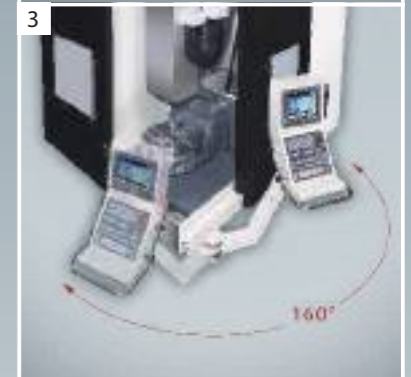
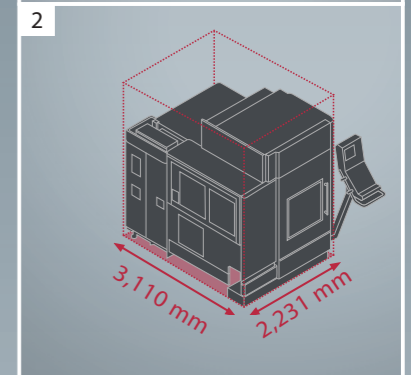

- 1 Double door design provides convenient work piece loading and unloading space.
- 2 Optimal compact structure design minimizes foot print increases the factory space efficiency.
- 3 Controller panel adopts 160° swivel design which ensures convenient operation.
- 4 High efficiency 32T arm type ATC system is equipped as standard accessory. 40T / 60T is also available for option.

FCV-620 Series

High Speed 5-Axis Machining Center

Guided by Finite Element Analysis and utilizing high tension Meehanite casting structure allow one-piece bed, column and saddle to reach optimal design. Mechanical strength of machine can sustain extremely heavy cutting while maintaining long-term excellent accuracy. As a result, high rigidity structure of FCV-620 can also extend the life time of the tool usage.

- Movable column C-shape structure design provides the best structural rigidity and minimizes floor space at the same time.
- Column adopts one-piece thick ribs structure with 4 large-sized linear blocks well support saddle which remains steady while fast movement machining on Y-axis.
- All axes adopt roller type linear guide ways, featuring heavy cutting capability of box ways, and fast movement and low wear capabilities of linear guide way.
- X / Y / Z axes are direct driven by AC servo motor with absolute encoder, which provide powerful thrust and fast acceleration / deceleration movement with extreme accuracy.

36 m/min

X / Y / Z rapid feed rate



■ Linear Scale (Opt.)

The optional high resolution close-loop linear scale ensures excellent positioning and repeatability accuracy.

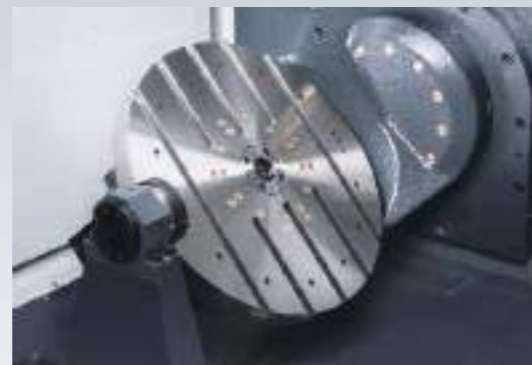

■ Rotary Working Table

Advanced design of rotary table is unilateral driven and supported by both sides of structure to provide outstanding performance and accuracy.

■ Extremely Short Spindle Overhang

Minimal spindle overhang design ensures structural rigidity of spindle and machining accuracy.

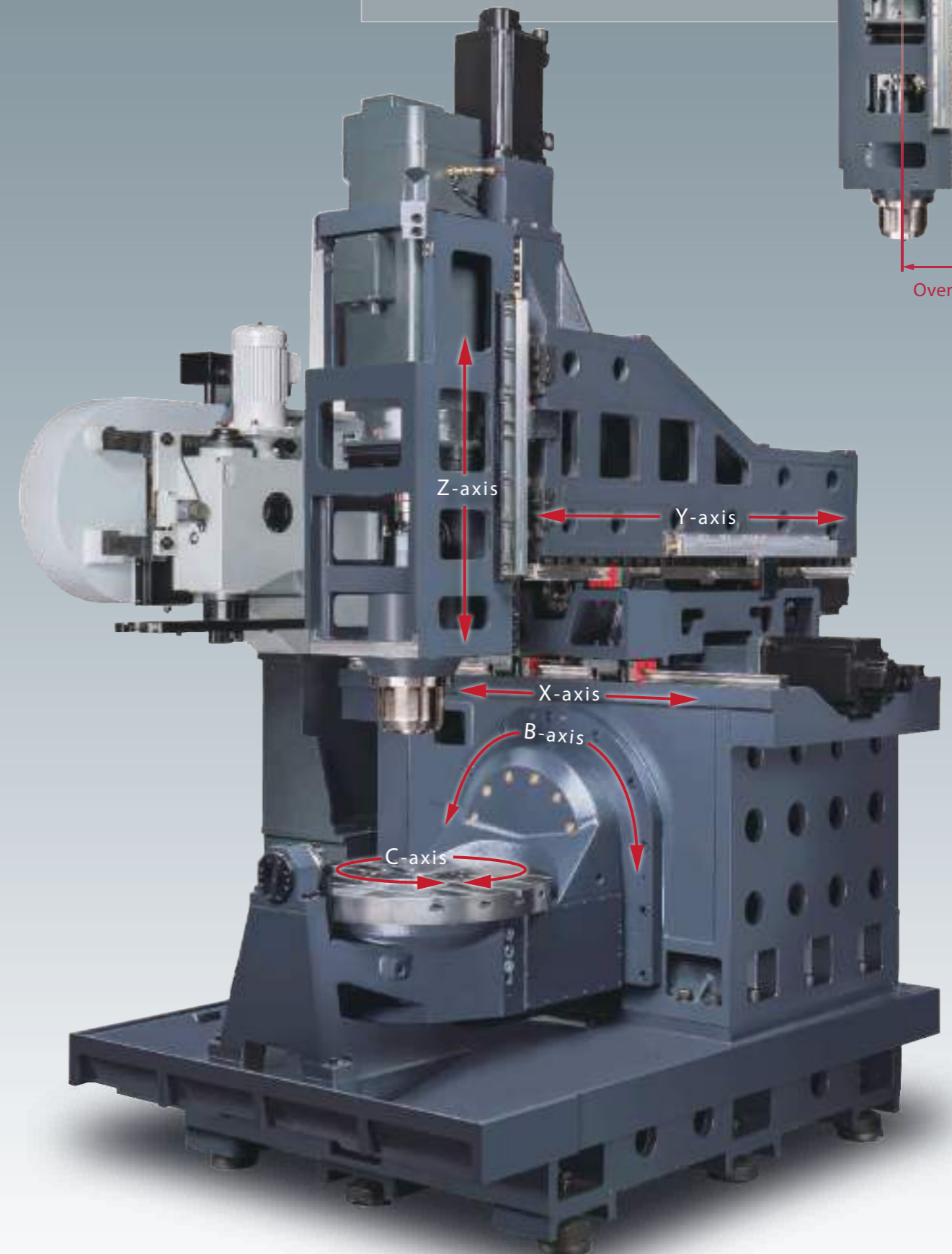
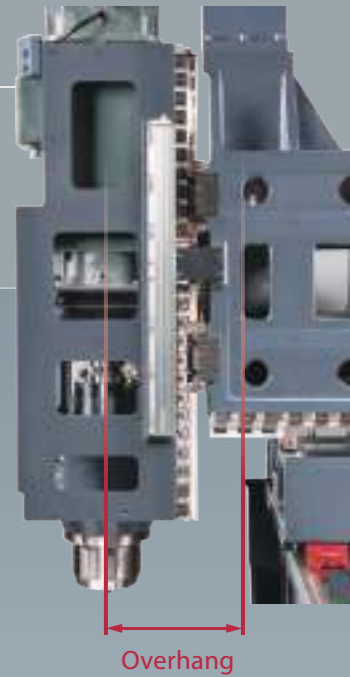

Ultimate Machining Power

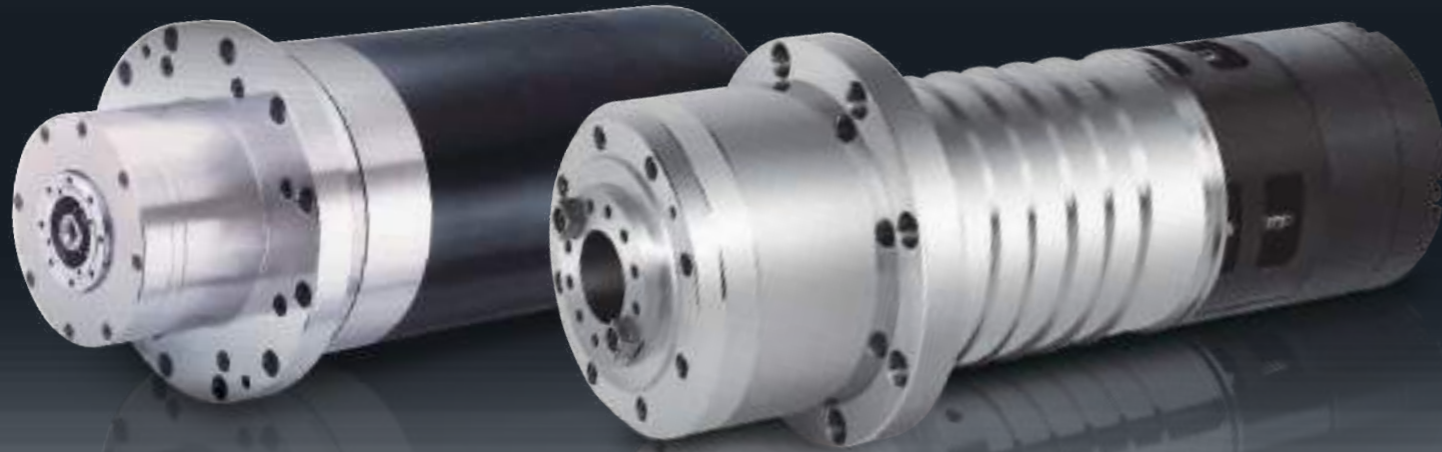

High speed built-in spindle

Built-in spindle efficiently lowers vibration of spindle while machining, which also extends life time of spindle and promote long period of machining accuracy.

High speed direct-driven spindle

Direct driven design efficiently isolates heat from motor, reduces thermal deformation and maintain long period of machining accuracy.

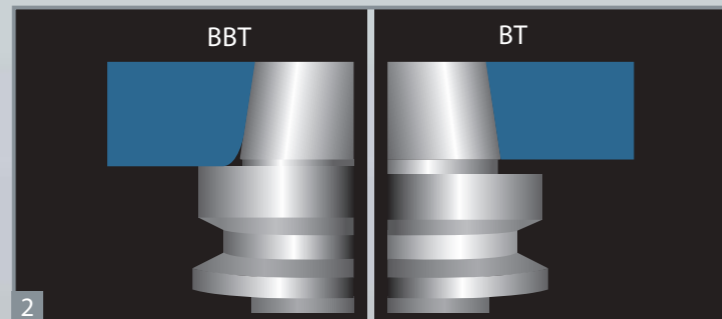

- Optional coolant through spindle. (20 bar / 70 bar)
- The inner taper of the spindle conforms with BBT40 tool to provide a firmer grip to the tools, which prevents tool vibration that affects machining accuracy. (HSK-A63 is optional)

12,000 rpm direct-driven Spindle

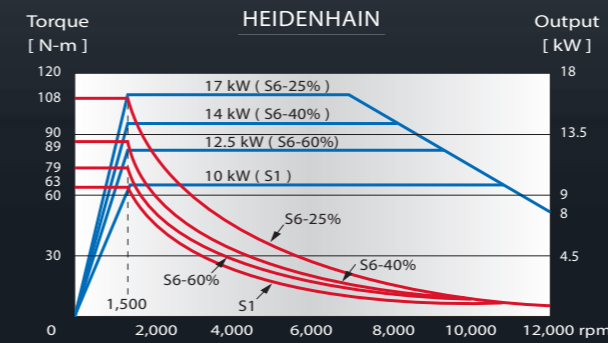

20,000 rpm Built-in Motorized Spindle

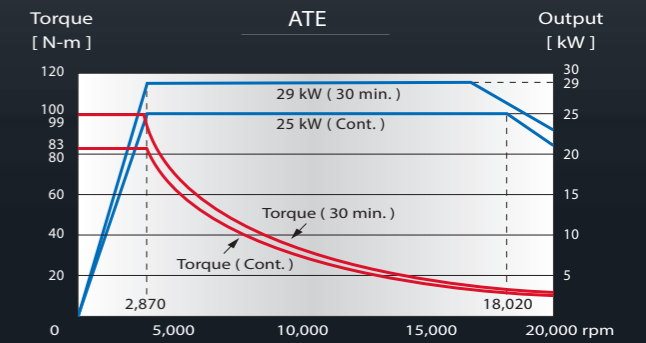

▶ other motors is also available

12,000 rpm direct-driven Spindle

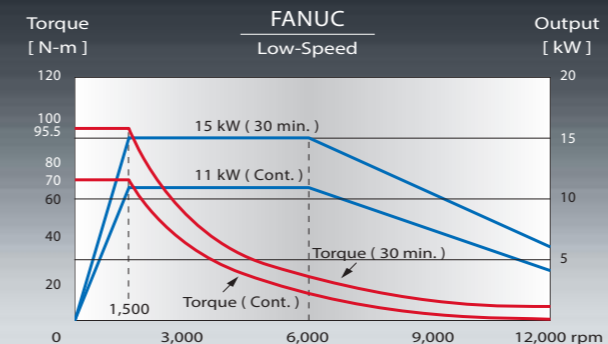

12,000 rpm direct-driven Spindle

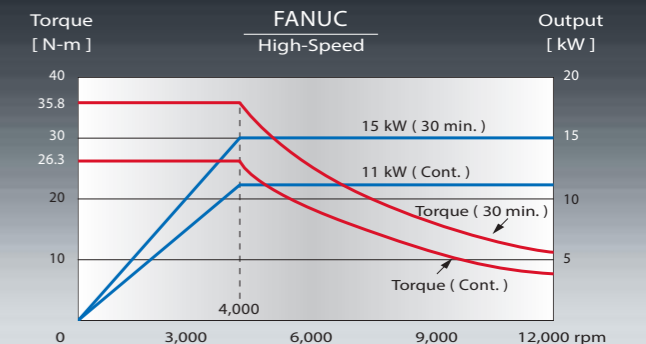

15,000 rpm direct-driven Spindle

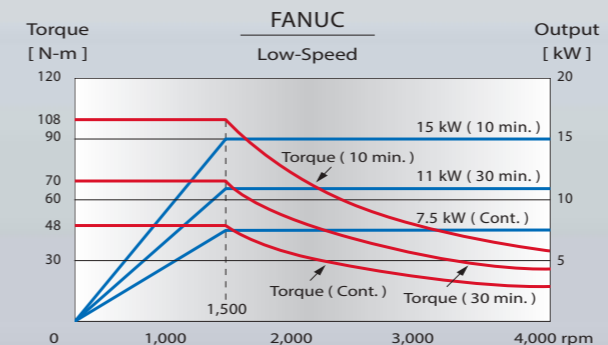

15,000 rpm direct-driven Spindle

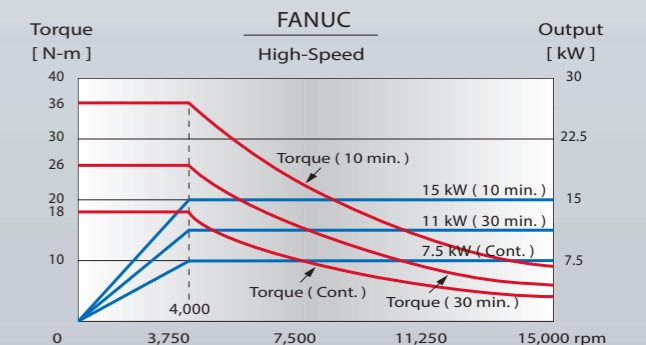

20,000 rpm Built-in Motorized Spindle

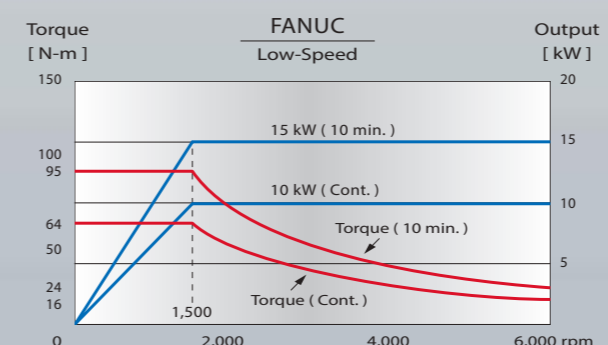

20,000 rpm Built-in Motorized Spindle

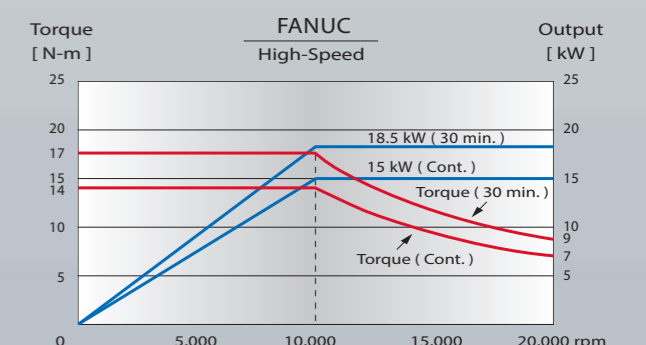



High Performance Rotary Working Table

Rotary table adopts one-piece spheroidal graphite casting iron which provides excellent ductility and great anti-vibration ability to ensure optimal machining accuracy.



Ultra performance B / C axes

- Worm gear driven by servo motor
- Circular hydraulic brake system
- HEIDENHAIN rotary linear scale as standard accessory



- Working table equips high rigidity tailstock support which ensures excellent machining accuracy during heavy loading or unbalancing force on table.

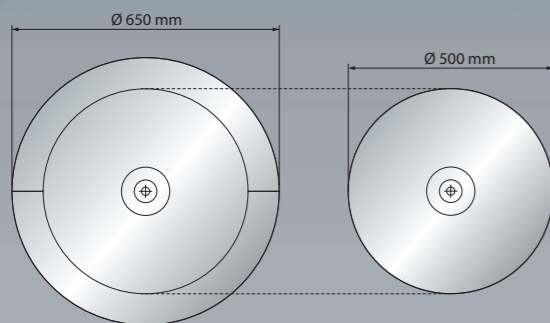

- Working table adopts detachable inner / outer plate design. Diameter of inner plate is Ø 500 mm. Depends on the size of work piece, the inner plate can unite with the outer plate, which diameter of plate can extend up to Ø 650 mm.

Dimensions

Table Dimensions

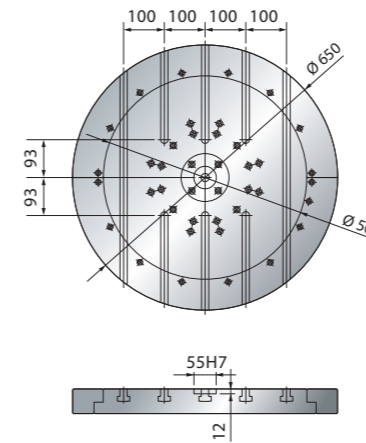

T-slot Dimensions

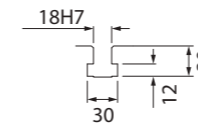

Machine Dimensions

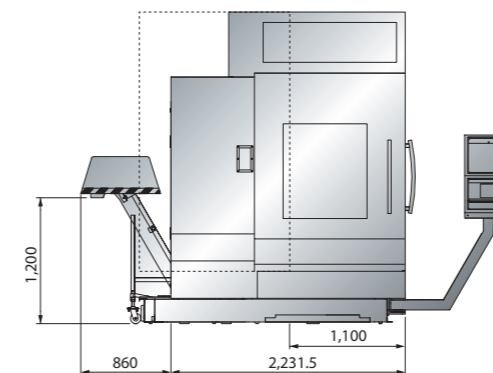
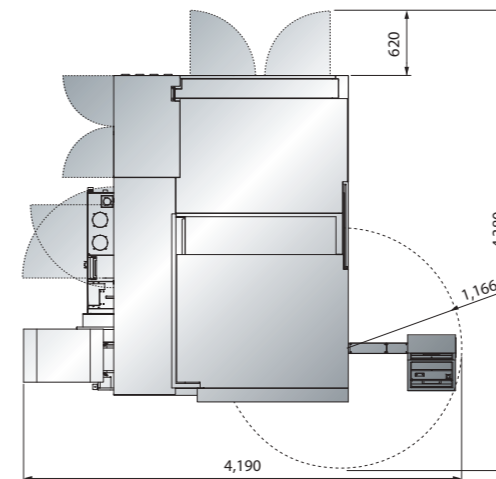

Tool Shank and Pull Stud Dimensions

BBT40

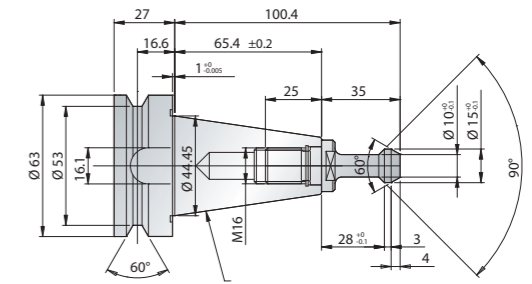

HSK-A63

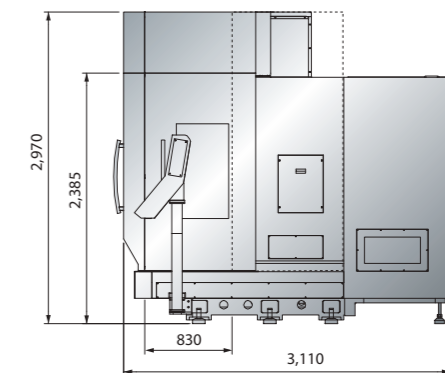
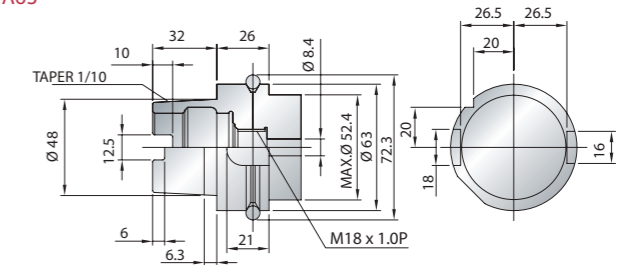

(unit: mm)

Dimensions

Interference Diagram

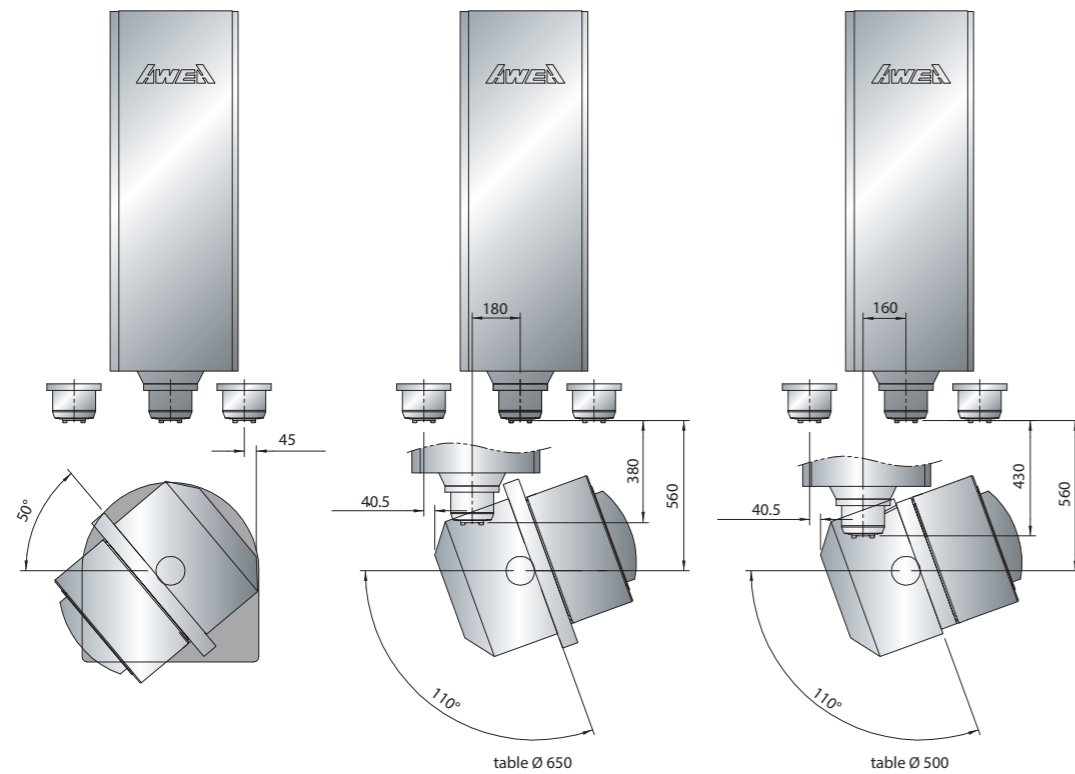

Working Area

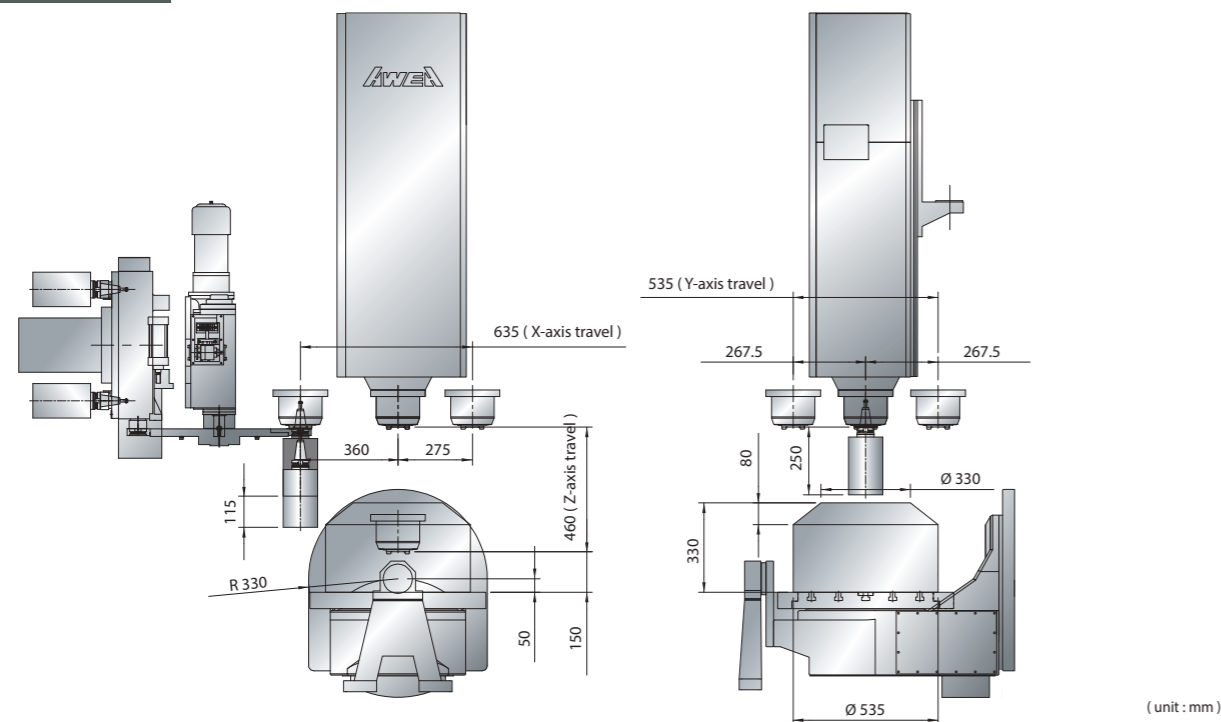

FCV-620

SPECIFICATIONS

X-axis travel	mm	635
Y-axis travel	mm	535
Z-axis travel	mm	460
B-axis swiveling range	degree	-50° ~ +110°
C-axis rotary range	degree	360°
B / C axes swiveling speed	rpm	25
Distance from spindle nose to table center	mm	150 ~ 610

WORKING TABLE

Table internal diameter	mm	Ø 500
Table external diameter	mm	Ø 650
Table load capacity (0°~45°)	kg	300
Table load capacity (45°~90°)	kg	200
T-slot (width x no. x space)	mm	18 x 5 x 100

SPINDLE

Spindle taper		BBT40 / HSK-A63
Spindle speed	rpm	Direct drive spindle 12,000 (15,000) Built-in spindle 16,000 (20,000)
Spindle motor (cont. / 30 min)	kW	11 / 15 (FANUC 12,000 rpm)

FEED RATE

X / Y / Z axes rapid feed rate	m/min.	36
Cutting feed rate	m/min.	1-20

TOOL MAGAZINE

Tool magazine capacity	T	32 (40 / 60)
Max. tool diameter / adj. pocket empty	mm	Ø 75 / Ø 127
Max. tool length	mm	250
Max. tool weight	kg	6

ACCURACY

Positioning accuracy (VDI 3441)	mm	P ≤ 0.012 / Full Travel
Repeatability (VDI 3441)	mm	Ps ≤ 0.008

GENERAL

Control system		FANUC Oi-MF / HEIDENHAIN iTNC 530
Pneumatic pressure requirement	kg/cm ²	6
Power requirement	kVA	50
Machine weight	kg	8,500

Specifications are subject to change without notice.

Standard Accessories

- B / C axes rotary encoder
- Spindle cooling system
- Spindle air curtain
- Coolant nozzle around spindle
- Centralized automatic lubricating system
- Chain type 32T tool magazine
- Coolant equipment system (Pump & tank)
- Caterpillar type chip conveyor and bucket
- Roof enclosed splash guard
- AC cooler for electrical cabinet
- Water gun and air gun for cleaning
- LED work light + LED tube
- Standard RS-232 transmission interface + network interface card (NIC)
- Tool box and anchor bolts
- Operation manual + maintenance guide
- Chips wash down
- Alarm light
- HEIDENHAIN iTNC 530 control system
- Direct drive 15,000 rpm

Optional Accessories

- Built-in 16,000 / 20,000 rpm
- Coolant through spindle
- Spindle thermal compensation
- Automatic power off system
- X / Y / Z axes linear scale
- Chain type 40 / 60 T tool magazine
- Oil skimmer
- Automatic tool length measurement
- Automatic work piece measurement
- Transformer