

## GRANDIS DECARBONISER

Specifically designed for larger catering establishments and bakeries, the Grandis Decarboniser provides efficient and effective decarbonising and degreasing of a wide range of kitchen equipment. The Grandis Decarboniser tank is fully insulated and double skinned ensuring it provides superior efficiency and reduced environmental impact. With an integrated digital temperature control unit, the Grandis is exceptionally easy to use. Perfect for any large kitchens including pubs, hotels, restaurants and bakeries.



### PERFORMANCE SPECIFICATIONS

Energy Efficiency	Consumes approximately 32kWh to reach operating temperature. Once operating temperature is reached consumes approximately 0.41kWh/h or 9.84kWh over 24 hours. At 15 pence per unit of electricity this equates to £4.80 to heat up and £1.50 per 24 hours.
Operating Time	Takes approximately 6 hours to raise water temperature from 20 degrees to 80 degrees centigrade. For heavy decarbonisation a soak time of between 10-12 hours is recommended. For average decarbonisation a soak time of 6-8 hours is recommended. For light decarbonisation and/or degreasing a soak time of 1-2 hours is recommended.
Temperature Control	Digital control unit, factory set at 80°C, adjustable between 60°C - 85°C
Mobility	Fully mobile with 4 x 80mm heavy duty castors, front two are braked
Insulation	Double-skinned and fully insulated tank, recessed and insulated lid prevents heat and condensation escaping.
Ergonomics	Robust, single handled lid with stay-locking mechanism. Heavy duty internal basket with ergonomic, hinged handles for safe tank loading.
Country of origin	Manufactured in the UK

### CHEMICAL SPECIFICATIONS

Composition	Powder
Environmental Impact	Biodegradable, non-caustic
Fragrance	Lemon-scented

For more information on ingredients, hazard statements and safety procedures please download the [Decarb IT Decarbonising Powder Safety Data Sheet](#).

## TECHNICAL SPECIFICATIONS

Capacity 320Ltr to maximum fill line

### Dimensions (external)

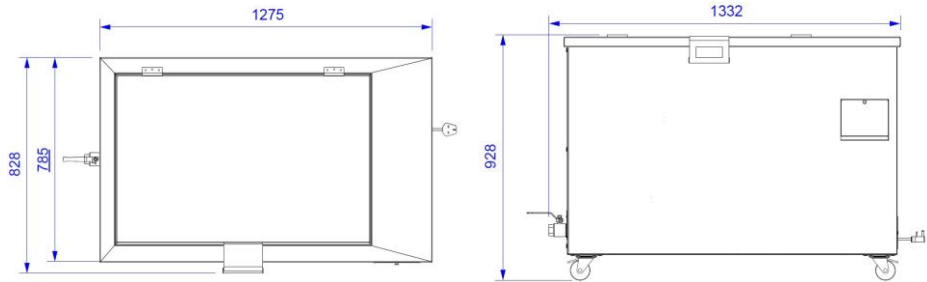

### Dimensions (Internal)

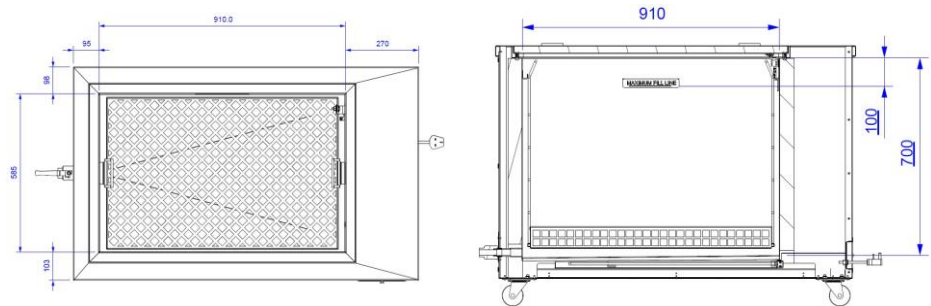

Weight 99kg

Voltage 220V/240V 1 phase 50Hz. 2.5 kW loading 12.6Amps approx.

Warranty Purchase: 1 year. Hire: Full length of contract

Cable 5 metres with 13 amp moulded UK (BS 1363) plug fitted

Main construction Grade 304, 16-gauge stainless steel

Element Dry, quick-fit, dual element mounted on a slide out tray.

Drainage Includes 1" ball tap for drainage, no plumbing required. Must be drained into a wastewater drain only.

For more information including other products available and pricing, please visit [www.decarbit.co.uk](http://www.decarbit.co.uk)