

- w** Ideally suited to high volume batch throughputs.
- w** Very efficient fluidised mixing of fragile materials with varied densities and particle size (flakes, powders, granules).
- w** Blades are of a twin, overlapping multi paddle design for gentle mixing.

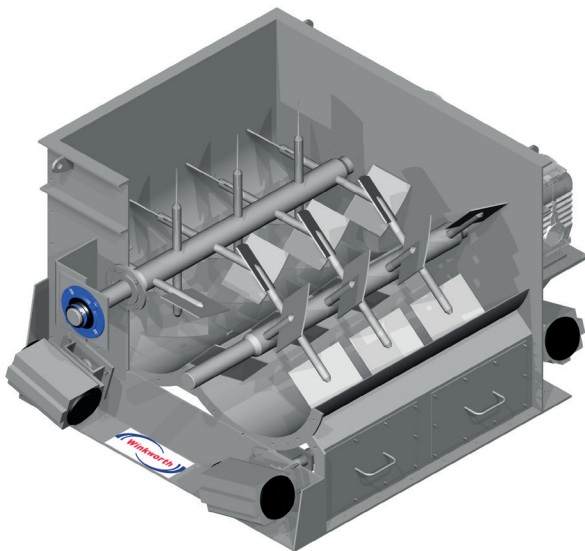

“ For the past 20 years we have been using **Winkworth** Twin Shaft mixers. By far they are the best mixer for mixing our materials. It is ideal for the quick and efficient mixing of the component ingredients without damaging the overall mix. ”

Winkworth TS Fluidising mixers are ideal for:

Cement
Flooring materials
Dry mortars
Abrasives
Ceramics
Road linings

Pet foods
Horse feeds
Poultry feeds
Fat coatings
Cereals

Pigments
Detergents
Fertilisers
Pesticides
Peat moss

Cake mixes
Coffee
Mueslis
Fruit mixes
Frozen vegetables/rice

Winkworth Machinery Ltd
Mixer House
Stroudley Road, Basingstoke
Hampshire RG24 8FW



Mixing all ways



- w Very rapid mixing to a high degree of homogeneity. Typical mix times of 10 - 30 seconds.
- w The **Winkworth** TS mixer gives a virtually complete discharge in seconds.

Features	Std	Option	Sizes
Fabricated in stainless steel	✓		20 litre to 2000 litre working volume (TS20 to TS2000)
Full length bomb doors for discharge	✓		
Drive from geared motor for same speed on each blade	✓		
Part fixed, part hinged lid	✓		
Multi paddle overlapping blades	✓		
Alternative lid designs		●	
Retractable design		●	
Adjustable packing glands		●	
Spray bars for liquid addition (with atomising option)		●	
Side access doors for ease of cleaning		●	
Heating panels		●	
Various internal and external finishes		●	
Heavy duty models for more dense products		●	
ATEX certified models		●	

At **Winkworth** we design each machine to suit your specific needs. The abbreviated option chart (above) is a guide to assist with developing the specification of your machine. To get your project started please call our sales team who will be delighted to help you.



Winkworth are application specialists in the complex and challenging world of mixing. Since 1924, years of experience, knowledge and client feedback have enabled **Winkworth** to design and manufacture bespoke mixing machinery for almost every mixing need.

Winkworth's current range includes the expertise and products originating from BPT Skerman and Premier Colloid Mills. For high shear in-line mixing we offer Ystral products and for low shear we have the Lindor "gentle touch" rotary drum blenders.

This complements the extensive range of proprietary mixer designs which are extensively used across all industries for mixing stiff gums, pastes, powders, liquids, etc, most of which are available at our Mixing Test Centre at our Basingstoke HQ.