

NOTES:

- 1) CLOSED CELL EPDM SPONGE RUBBER (0.750 G/CM<sup>3</sup>)
- 2) 90 DUROMETER EPDM DENSE RUBBER (1.250 G/CM<sup>3</sup>)
- 3) 3/4" ST-1200 3M HEAT ACTIVATED TAPE (0.013 LB/FT)

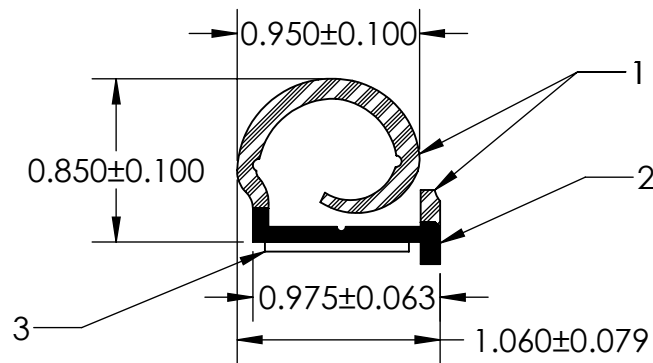
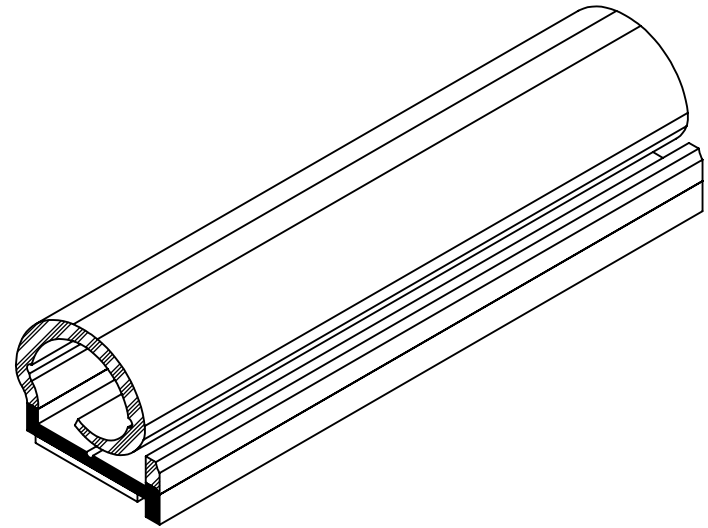

**UNI-GRIP, INC.**

9823 STATE ROUTE 53 N  
UPPER SANDUSKY, OHIO 43351

REVISION BLOCK				PROPRIETARY AND CONFIDENTIAL:	UNLESS OTHERWISE SPECIFIED:	TITLE:		
REV.	DATE	REVIEWED BY	CHANGES MADE	THE INFORMATION CONTAINED IN THIS DRAWING IS THE SOLE PROPERTY OF UNI-GRIP, INC. ANY REPRODUCTION IN PART OR AS A WHOLE WITHOUT THE WRITTEN PERMISSION OF UNI-GRIP, INC. IS PROHIBITED.	DIMENSIONS ARE IN INCHES TOLERANCES PER ARPM CLASS 3	UNI-SEAL B		
A								
B					WEIGHT	SIZE <b>A</b> DWG. NO. UG-1-US-625-TP-002      REV <b>A</b>		
C					0.117 LB/FT			
D					ASTM D1056	SCALE: 1:1      DR. BY C. VENT      DATE 5/21/2019      SHEET 1 OF 1		
E				2A4				
				DOCUMENT CONTROL NUMBER	ASTM D2000			
				UG-1-EN-001-FR-(103018)	3BA711 A14 B13 C12 F17			
P:\Engineering\Prints\Uni-Seal\UNI-SEAL B UG-1-US-625-TP-002								