

# MOD-U-SERVE

## DROP-IN RECESSED FROST TOP FOR 18 X 26 SHEET PANS REFRIGERATED - SLIMLINE

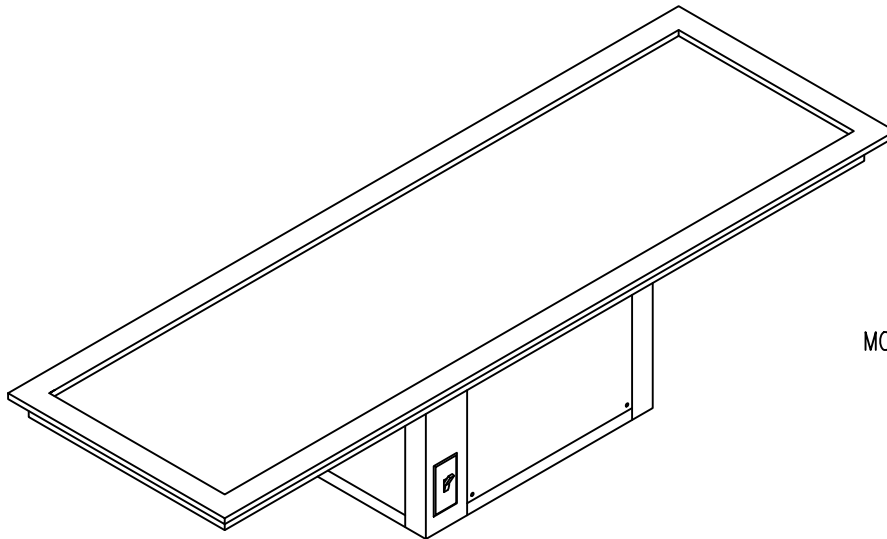

MODEL #DI-CFSP-2-S

SHOWN WITH OPTIONAL ON/OFF SWITCH

<u>MODEL</u>	<u>LENGTH</u>	<u>PANS</u>	<u>HP</u>	<u>VOLTS</u>	<u>PHASE</u>	<u>AMPS</u>	<u>CORD/CAP</u>
DI-CFSP-1-S	29.0"	1	1/4	120	1	8.0	NEMA 5-15P
DI-CFSP-2-S	55.0"	2	1/4	120	1	8.0	NEMA 5-15P

### STANDARD FEATURES

COLD PAN INTERIOR: 16 gauge stainless steel fully welded interior liner integral with top flange.

COLD PAN EXTERIOR: 18 gauge galvanized jacket over minimum 1" thick foam insulation.

REFRIGERATION: 3/8" copper bottom mounted coil with thermal mastic applied to increase surface area.  
Self contained condensing unit with receiver and expansion valve operation.

ELECTRICAL CONNECTION: 6' cord and plug set (NEMA-15).

THERMOMETER: Unit complete with digital thermostat/controller.

STAINLESS STEEL SPECIFICATION: All stainless steel to be type 304 with number 3 finish.

### OPTIONAL FEATURES

ON/OFF TOGGLE SWITCH: Factory mounted on/off lighted toggle switch.

# MOD-U-SERVE

## DROP-IN RECESSED FROST TOP FOR 18 X 26 SHEET PANS REFRIGERATED - SLIMLINE

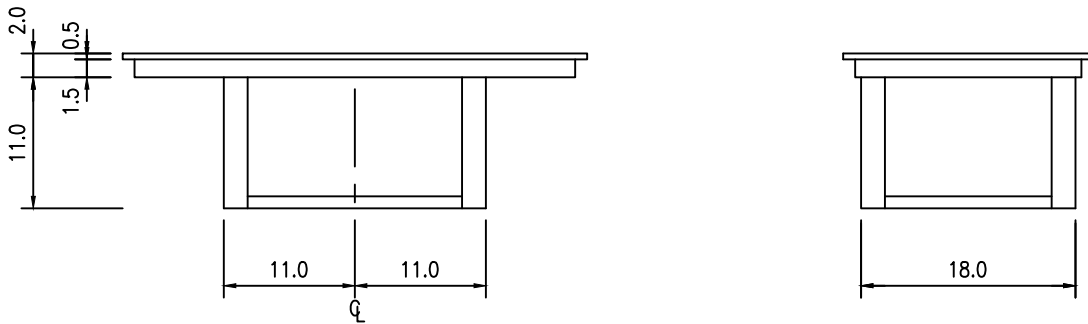
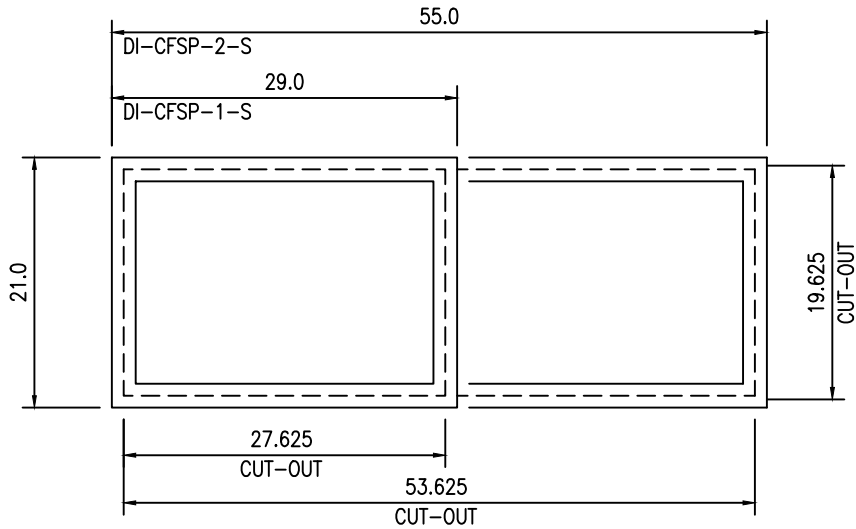

<u>MODEL</u>	<u>LENGTH O.A.</u>	<u>WIDTH O.A.</u>	<u>INSIDE DIM.</u>	<u>CUT OUT DIM.</u>
DI-CFSP-1-S	29.0"	21.0"	17.0" X 25.0"	19.625" X 27.625"
DI-CFSP-2-S	55.0"	21.0"	17.0" X 51.0"	19.625" X 53.625"