

MOD-U-SERVE

DROP-IN RECESSED FROST TOP REFRIGERATED

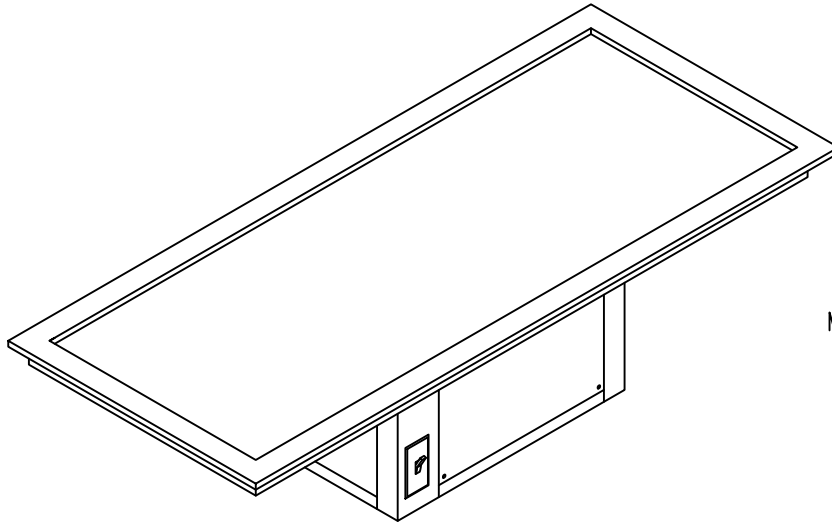

MODEL #DI-FR4

SHOWN WITH OPTIONAL ON/OFF SWITCH

<u>MODEL</u>	<u>LENGTH</u>	<u>WELLS</u>	<u>HP</u>	<u>VOLTS</u>	<u>PHASE</u>	<u>AMPS</u>	<u>CORD/CAP</u>
DI-FR2	28.5"	2	1/4	120	1	8.0	NEMA 5-15P
DI-FR3	42.5"	3	1/4	120	1	8.0	NEMA 5-15P
DI-FR4	56.5"	4	1/4	120	1	8.0	NEMA 5-15P
DI-FR5	70.5"	5	1/3	120	1	6.0	NEMA 5-15P
DI-FR6	84.5"	6	1/3	120	1	6.0	NEMA 5-15P

STANDARD FEATURES

COLD PAN INTERIOR: 16 gauge stainless steel fully welded interior liner integral with top flange.

COLD PAN EXTERIOR: 18 gauge galvanized jacket over minimum 1" thick foam insulation.

REFRIGERATION: 3/8" copper bottom mounted coil with thermal mastic applied to increase surface area.
Self contained condensing unit with receiver and expansion valve operation.

ELECTRICAL CONNECTION: 6' cord and plug set (NEMA-15).

THERMOMETER: Unit complete with digital thermostat/controller.

STAINLESS STEEL SPECIFICATION: All stainless steel to be type 304 with number 3 finish.

OPTIONAL FEATURES

ON/OFF TOGGLE SWITCH: Factory mounted on/off lighted toggle switch.

MOD-U-SERVE

DROP-IN RECESSED FROST TOP REFRIGERATED

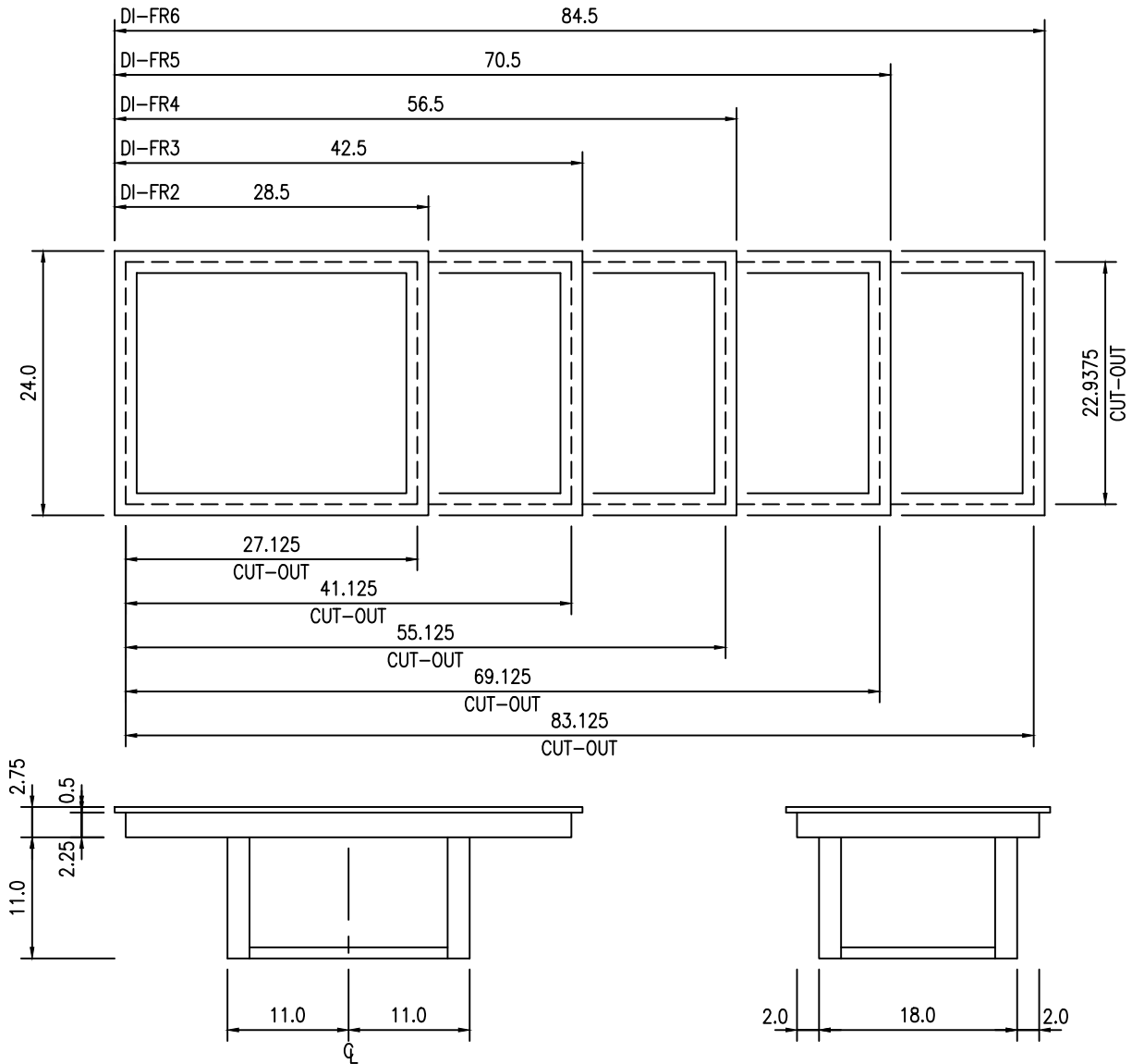

MODEL	LENGTH O.A.	WIDTH O.A.	INSIDE DIM.	CUT OUT DIM.
DI-FR2	28.5"	24.0"	24.5" X 20.0"	22.9375 X 27.125
DI-FR3	42.5"	24.0"	38.5" X 20.0"	22.9375 X 41.125
DI-FR4	56.5"	24.0"	52.5" X 20.0"	22.9375 X 55.125
DI-FR5	70.5"	24.0"	66.5" X 20.0"	22.9375 X 69.125
DI-FR6	84.5"	24.0"	80.5" X 20.0"	22.9375 X 83.125