

MOD-U-SERVE

MOBILE BREAKFAST CART

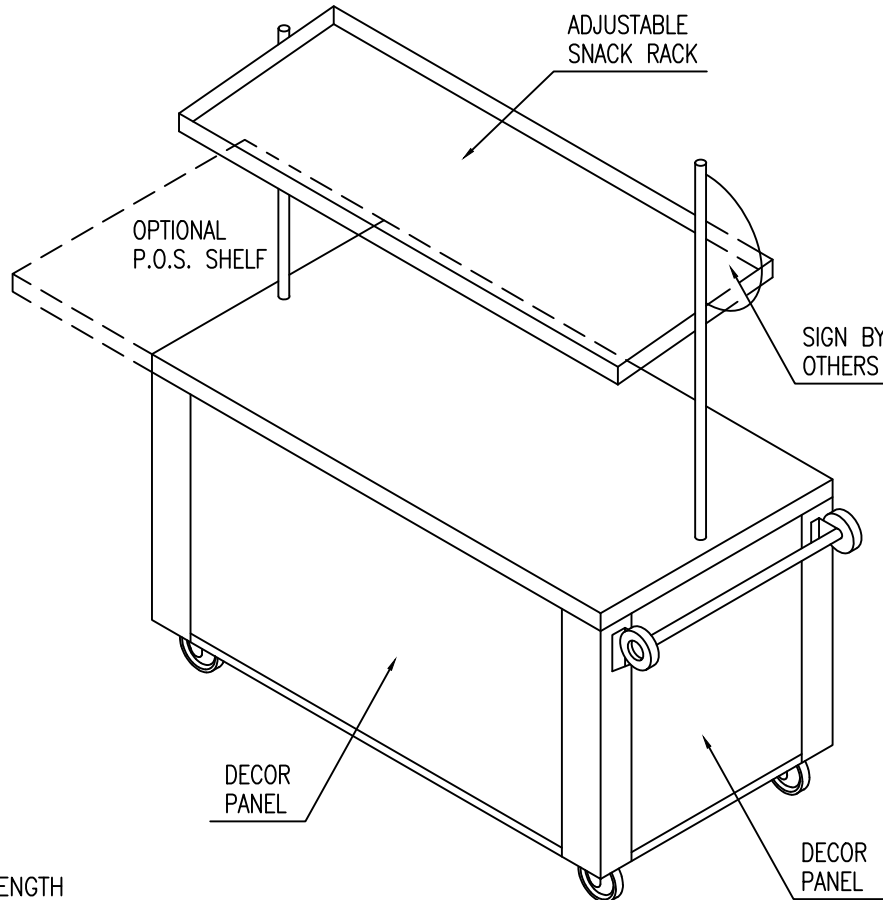

<u>MODEL</u>	<u>LENGTH</u>
MCT-BRKC	58.0"

<u>WIDTH</u>	<u>HEIGHT</u>
30.0"	36.0"

STANDARD FEATURES

FRAME: Featuring all stainless steel construction utilizing 16 gauge stainless steel top and corners, 18 gauge bottom channels, corners, undershelf, and snack rack, and 1 1/4" square tubing top frame.

CASTERS: Heavy duty 5" diameter plate casters with swivel/brake casters at all corners.

SIDE PANELS: Decor panels on three sides and sign by others.

OVERSHELF POST: 1" diameter s/s tubing.

STAINLESS STEEL SPECIFICATION: All stainless steel to be type 304 with number 3 finish.

OPTIONAL FEATURES

P.O.S SHELF: Featuring 16 gauge stainless steel construction, mounted on fold down brackets.