

MOD-U-SERVE

MOBILE 175 LB ICE BIN MODEL MCT-ICE-175

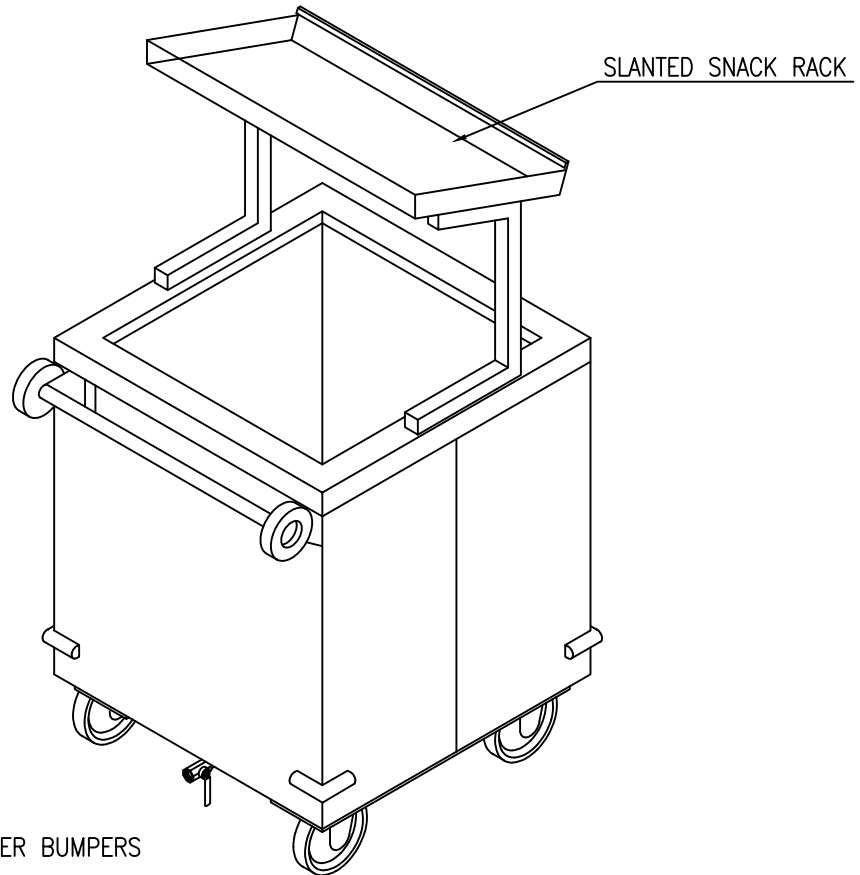

* ADD 2" FOR CORNER BUMPERS

<u>MODEL</u>	<u>LENGTH</u>	<u>WIDTH</u>	<u>HEIGHT</u>
MCT-ICE-175	26"*	26"*	36"

STANDARD FEATURES

- CASTERS: Heavy duty 5" diameter plate casters with locking brakes on all four corners.
- INTERIOR LINER: 18 gauge stainless steel fully welded and watertight.
- OUTER CONSTRUCTION: All stainless steel outer shell and bottom framing.
- DRAIN CONNECTION: 1" stainless steel nipple welded to interior liner with ball valve.
- INSULATION: Full 2" thick high pressure foam.
- PUSH HANDLE: Stainless steel handle with donut type rubber bumpers.
- CORNER BUMPERS: Rubber bumper located at each corner.
- FALSE BOTTOM: Stainless steel removable perforated false bottom.
- STAINLESS STEEL SPECIFICATION: All stainless steel to be type 304 with number 3 finish.

OPTIONAL FEATURES

- BI-FOLD LID: All stainless steel insulated bi-fold lid.

MOD-U-SERVE

MOBILE 175 LB ICE BIN MODEL MCT-ICE-175

