

MOD-U-SERVE

MODULAR - HOT FOOD UNIT RECESSED FOR SHEET PANS

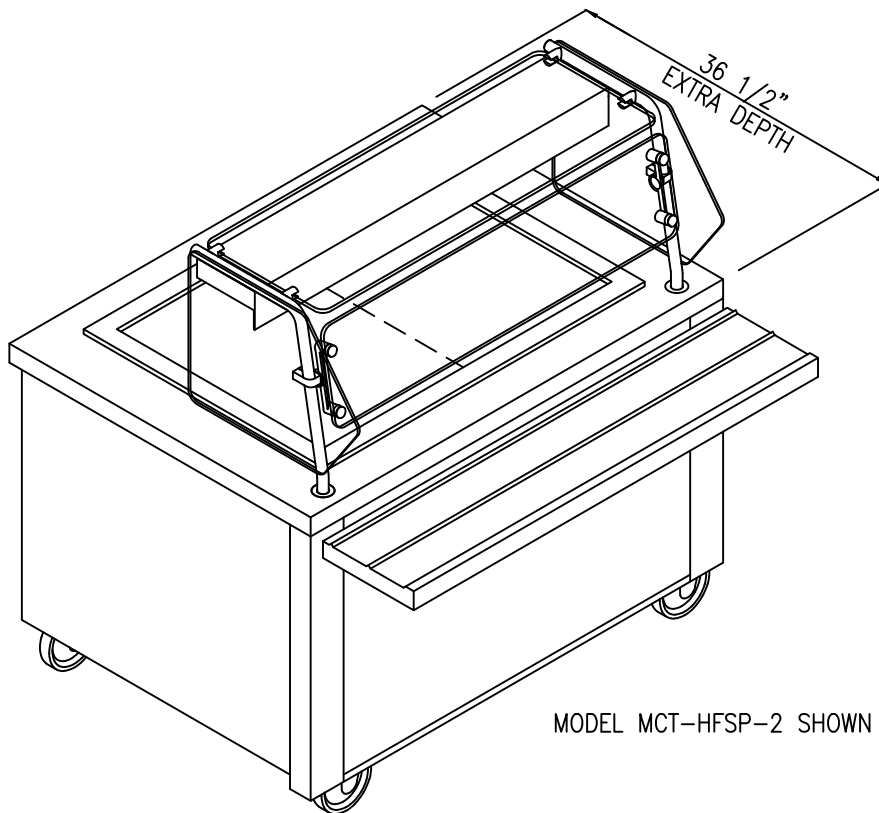

MODEL MCT-HFSP-2 SHOWN

LIGHTS ONLY/NO HEAT LAMP

MODEL	LENGTH	PANS	WATTS	VOLTS	PHASE	AMPS	CORD/CAP
MCT-HFSP-1	32"	1	300	120	1	2.5	NEMA 5-15P
MCT-HFSP-2	50"	2	600	120	1	5.0	NEMA 5-15P
MCT-HFSP-3	68"	3	900	120	1	7.5	NEMA 5-15P

LIGHTS AND HEAT LAMP

MODEL	LENGTH	PANS	WATTS	VOLTS	PHASE	AMPS	CORD/CAP
MCT-HFSP-1	32"	1	550	120	1	4.6	NEMA 5-15P
MCT-HFSP-2	50"	2	1175	120	1	9.8	NEMA 5-15P
MCT-HFSP-3	68"	3	1836	120	1	15.3	NEMA 5-20P

STANDARD FEATURES

FRAME: Featuring frameless construction utilizing 16 gauge stainless steel corner mullions with top and bottom horizontal members of 16 gauge stainless steel.

CASTERS: Heavy duty 5" diameter adjustable polyurethane casters with brakes all the way around.

TOP: 14 ga. stainless steel with 2" turndown on all sides and sound deadening applied between top and frame.

SNEEZE GUARD: Elite 4 custom guards with 1" round stainless steel tubing post. 3/8" tempered glass NSF rated with optional LED light fixtures.

FRONT BODY PANEL: Removable front panels in a wide array of options.

TRAYSLIDE: 14 gauge stainless steel with inverted vee ridges on fold-down brackets.

HOT PAN: 1/2" deep stainless steel pan sized for 18 x 26 sheet pans for.

STAINLESS STEEL SPECIFICATION: All stainless steel to be type 304 with number 3 finish.

MOD-U-SERVE

MODULAR - HOT FOOD UNIT RECESSED FOR SHEET PANS

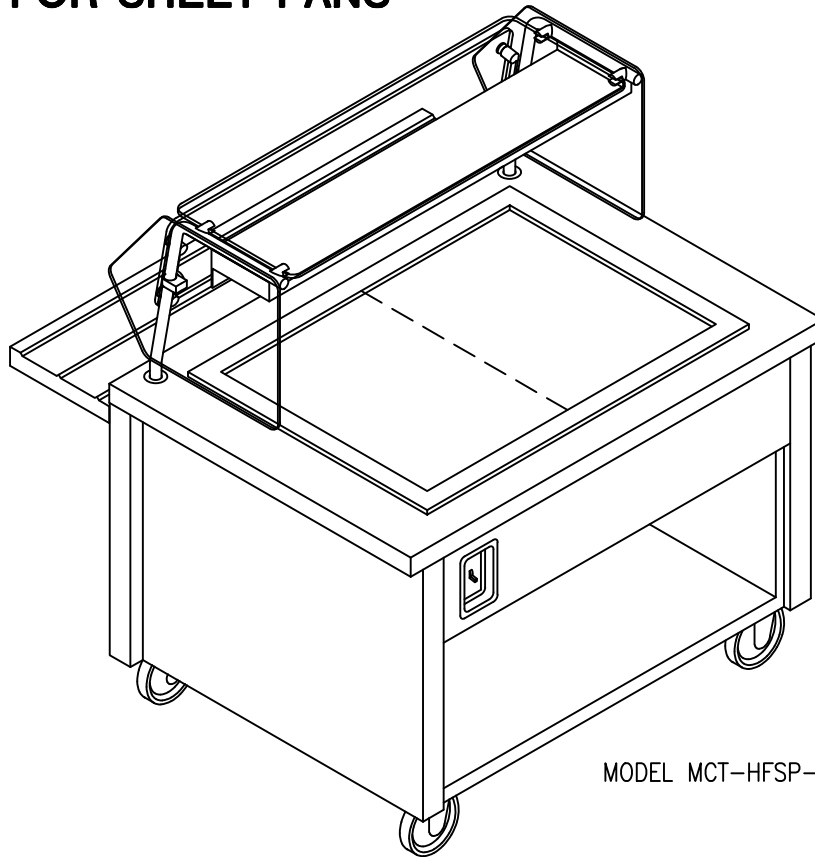

MODEL MCT-HFSP-2 SHOWN

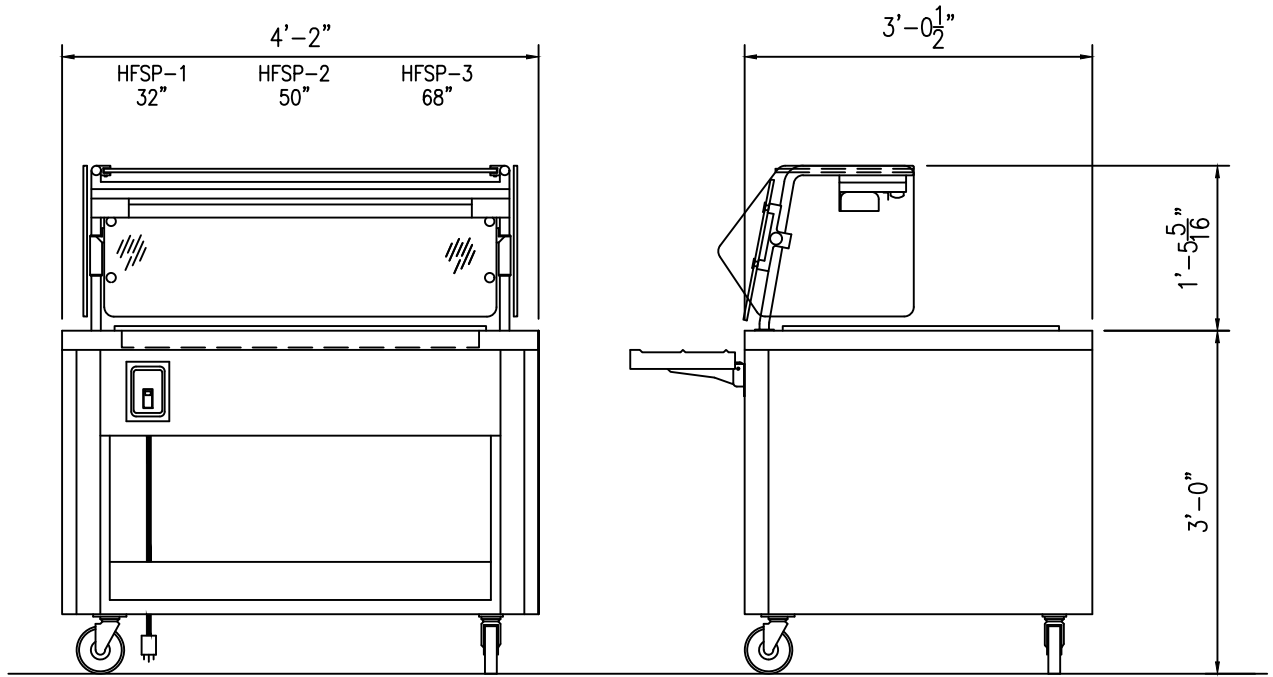

FILE: MCT-HFSP-2