

1. Concrete strength to be 5,000 psi after 28 days
2. Manhole wall, transitions, conical sections, and bases shall conform to ASTM C478. Conical sections shall be designed to meet or exceed all requirements of the latest ASHTD H5-20 Loading.
3. Joints between the precast units shall be sealed with flexible watertight rubber gaskets conforming to ASTM C 990 or C443 and wrapped externally, ASTM C 877 (tube III - Chemically Bonded Adhesive Butyl Bands) - Applied by installation contractor.
4. Sewer pipe to manhole connections shall be sealed with Integally Cast Flexible connectors according to section C923
5. All manholes shall be precast with Xipex and ConShield per Section 803. All interior surfaces (including benches) of new sanitary sewer manholes at force main entry locations and one manhole down stream of the force main entry shall be given and interior coating of Pilgrim Liner Guard 100C per System 108.
6. Manholes of 60" Dia. shall be used for 16" up to 24" pipe.
7. External Wrap Per Section 803 provided by contractor
8. Manholes shall not include steps.

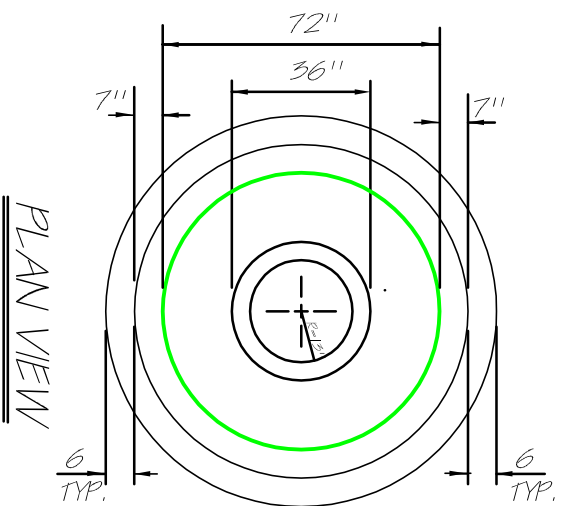

MANHOLE
6' Dia.
by: THOMAS F. PERTUIT, P.E.

WASTEWATER TREATMENT OF LOUISIANA, INC.

17188 Airline Hwy, Ste M-157 Prairieville, LA 70769
PH 225-673-3156