

1. Concrete strength to be 5,000 psi after 28 days
2. Manhole wall, transitions, conical sections, and bases shall conform to ASTM C478. Conical sections shall be designed to meet or exceed all requirements of the latest AASHTO H5-20 Loading.
3. Joints between the precast units shall be sealed with flexible watertight rubber gaskets conforming to ASTM C 990 or C445 and wrapped externally, ASTM C 877 (type III -Chemically Bonded Adhesive Butyl Bands) -Applied by installation contractor.
4. Sewer pipe to manhole connections shall be sealed with Internally Cast Flexible connectors according to section C925
5. All manholes shall be precast with Xypex and ConShield according to Section 803. All interior surfaces (including benches) of new sanitary sewer manholes at force main entry locations and one manhole down stream of the force main entry shall be given and interior coating of Pilgrim Liner Guard 100C in accordance with System 108.
6. Manholes of 48" Dia. shall be used for 16" pipe or less
7. External Wrap Per Section 803 provided by contractor
8. Manholes shall not include steps.

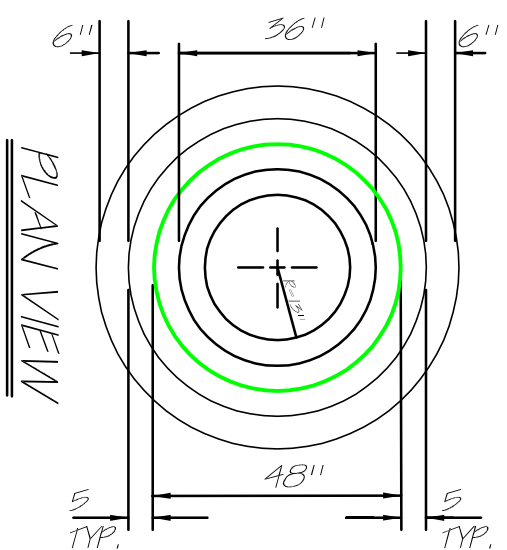

WASTEWATER TREATMENT OF LOUISIANA, INC.

17188 Airline Hwy, Ste M-157 Prairieville, LA. 70769
 PH 225-673-3156

48" MANHOLE
 CONCENTRIC MANHOLE
 by:
 THOMAS F. PERTUIT, P.E.