

WIRELESS PASSIVE INFRARED DETECTOR WITH PET IMMUNITY

«CN-PIR»

Installation Guide



1 Introduction

Wireless passive infrared detector «CN-PIR» (hereinafter, the Detector) is intended for detecting intrusion into a closed protected space and generating an alarm message.

The Detector highlights:

- generates status messages via a two-way wireless channel within the 433.05 – 434.79 MHz frequency range according to «CN-Contact-R» wireless two-way data exchange protocol;
- is intended to operate as a component of a system that is operated by any control panel (hereinafter, CP) supporting «CN-Contact-R» wireless two-way data exchange protocol;
- ensures case tamper protection;
- is resistant to the ambient light impact and radio interference;
- does not generate false alarms caused by the movement of:
 - a) short-haired pets weighting up to 20 kg (with temperature contrast 8 °C);
 - b) long-haired pets weighing up to 40 kg (with temperature contrast 6 °C);
- the Detector is installed directly on a wall or in a corner of a room.

2 Features of the Detector

- Dual-element pyrodetector.
- Distortions prevention in the detection zone by means of spherical lens.
- Pet immunity.
- Protection against ingress of insects to the pyroelectric.
- Pet immunity adjustment (10, 20 or 40 kg pet weight).
- Automatic switching to a backup operating frequency in case of an imperfect interference situation on the main one.
- Built-in main and backup power supply.

3 Specifications

Table 1

Features	Value
Detection zone size	10 x 10 m
Detection zones	8 long-range zones, 4 short-range zones
Maximum detection range	10 m
Pet immunity	Jumper «10kg» installed – 10 kg
	Jumper «10kg» removed – 20 kg (contrast 8 °C) or 40 kg (contrast 6 °C)
Operating temperature	from minus 20 °C to +55 °C
Dimensions, maximum	105 x 75 x 56 mm
Weight, maximum	0.1 kg
Battery life (under normal climatic conditions and with a radio exchange period equal to at least 30 sec)	up to 5 years
IP rating	IP41

The Detector is powered by a main lithium power-supply battery CR123A type and CR2450 backup one.

4 Scope of Delivery

Each Detector unit package contains the items listed in Table 2.

Table 2

Name	QNT
Wireless passive infrared detector «CN-PIR»	1 pc.
Screw 3-3x30.016	2 pcs.
Wall plug NAT 5x25 SORMAT	2 pcs.
CR123A lithium power supply battery	1 pc.
CR2450 lithium power supply battery	1 pc.
Wireless passive infrared detector «CN-PIR». Installation Guide	1 copy

5 Field of Application

The Detector can be installed in apartments, as well as in shops, offices, museums and industrial facilities. The Detector may be installed in premises, that are inhabited by pets weighing up to 40 kg (20 kg).

6 Informativity

The Detector ensures transmission and indication of the following messages:

- normal state message;
- alarm message;
- tamper message;
- main power-supply low-battery message;
- backup power-supply low-battery message;
- «Binding» mode indication;
- «Identification» mode indication;
- communication quality indication.

7 Detection Pattern

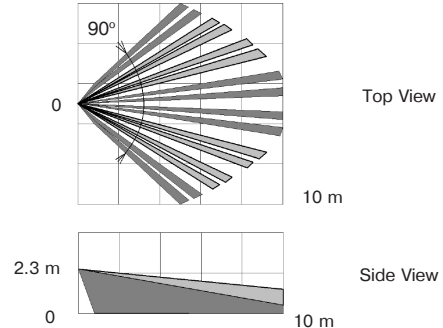

Figure 1

8 LED Indication

Table 3

Detector State	LED Indication	
	LED status	Operation mode
«Binding»	LED indicator blinks green	
«Alarm»*	LED indicator lights red for at least 0.5 sec	if indication is enabled
«Identification»	LED indicator blinks red and green alternately at 1 Hz frequency	by a command from the CP
Binding procedure completed	See «Communication Quality Appraising»	
Binding procedure completed	LED indicator lights red for 2 sec	

*) – Alarm indication is deactivated 15 min after the Detector cover is closed and activated after it has been opened or by a command from the CP.

9 Binding with the CP

The Binding procedure is intended for logging of the Detector in the CP and transmission of service information to it.

9.1 Prepare the CP for the Detector logging in accordance to the CP manual.

9.2 Install the CR2450 backup power-supply battery into the holder located on the reverse side of the Detector printed circuit board (PCB).

9.3 Install the PCB into the Detector case, and then install the CR123A main power-supply battery.

9.4 Blinking of the LED indicator green displays the Detector readiness for the binding procedure. In case the LED indicator does not blink, close the «Reset» contacts for a short period.

9.5 After a successful binding with the CP, the LED indicator lights red for 2 sec.

9.6 The «Binding» procedure is limited to 70 sec. After it expires, the Detector switches to the sleep mode. To resume the «Binding» mode, the «Reset» contacts should be temporary closed.

10 Choosing an Installation Place for the Detector

The Detector must be located in the radio-coverage zone of it's CP. Therefore, it is advisable to appraise quality of communication beforehand. The procedure of communication quality appraising is described in the chapter «Communication Quality Appraising».

When choosing the Detector installation place, it is advisable to take note of the fact that the detection zone may be limited by non-transparent objects (curtains, houseplants, cabinets, bookcases, etc.), as well as glass and mesh partitions. There must be no windows, air conditioners, space heaters or heating radiators in the Detector visibility zone. The presence of furniture items on which an animal may climb in the detection zone may cause a false alarm.

Recommended installation height – 2.3 m from the floor.

The Detector should be installed at least 0.5 m distance from electric cables.

11 Communication Quality Appraising

Before installing the Detector to its place of operation, it is advisable to appraise the CP communication quality as follows.

11.1 Prepare the Detector for operation and put it on its location place with a closed cover.

11.2 Open the Detector case, whereupon the Detector will indicate the quality of CP communication.

Table 4

LED indication	Communication Quality Appraisal	Recommendations
LED indicator blinks green three times	Excellent	Install the Detector at this place
LED indicator blinks green two times	Good	
LED indicator blinks green one time	Communication established	Choose another place of installation or use a repeater*)
LED indicator blinks red four times	No communication	
*) – Repeater «CN-RC»		

12 Installing the Detector

Before installing the Detector, remove its cover and the PCB. For this purpose:

- remove the cover of the Detector;
- loosen the screw fastening the PCB, move it upwards and remove it from the Detector base;
- drill the holes (Figure 2) in the base of the Detector case. They will be used for fastening the Detector;
- choose the installation place, mark out and drill the installation places in the wall with regard for the position of the holes on the Detector base;
- fasten the Detector base in the chosen place;
- reinstall the PCB;
- put on the cover.

Note – To exclude false alarms in the pet immunity mode, the Detector should be installed vertically.

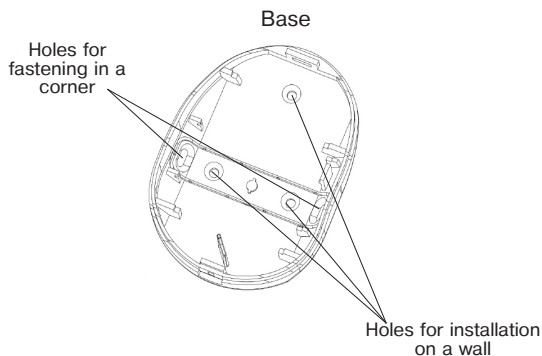

Figure 2

13 Functional Testing

In presence of the pets weighing up to 40 kg in the room, remove the «10 kg» jumper, in presence of the pets weighting less than 10 kg in the room, install the «10 kg» jumper.

It is advisable to remove the «10 kg» jumper in the premises with a high interference level.

Start walking across the detection zone. After 3 – 4 steps across the detection zone, the Detector should display the detection by the LED indicator red blink. Wait for 10 sec and continue walking across the detection zone. There must be no indication in absence of moving objects in the room. If the Detector fails to detect moving objects in the detection zone, its position on the swivel bracket should be changed.

14 Detector Behavior

14.1 The Detector is powered on and off by installation and removal of the main power-supply battery.

14.2 After loss of communication with the CP, the Detector will continue to search for the CP. In case the CP is disabled for a long time, it is recommended to power off the Detector (see Cl. 14.1).

14.3 It must be taken into account, that in case of the Detector operation within +5 °C to minus 20 °C temperature range, the battery life may be less than 5 years.

ATTENTION! The Detector must be checked at least annually in order to test its performance.

15 Storage and Transportation

15.1 The Detectors in their original packing may be shipped by any transport means in covered vehicles (in railway, cars, trucks, sealed heated compartments of aircraft, ship cargo holds, etc). The Detector is resistant to:

a) transport jolting with the acceleration 30 m/sec² with impact frequency from 10 to 120 impacts/sec or 15000 impacts with the same acceleration;

b) the ambient temperature minus 50 ... +50 °C;

c) relative air humidity (95 ± 3) % at the ambient temperature +35 °C.

15.2 After transportation under the conditions different to exploitation conditions the Detector shall be ready to operate after a maximum of six hours.

15.3 The storage room shall be free from current-conducting dust, acid vapors, alkali and gases that cause corrosion and destroy insulation.

16 Manufacturer's Guarantees

16.1 «RIELTA» JSC guarantees conformity of the Detector to its Technical Specifications if conditions of transportation, storage, assembling and operation are observed. The guaranteed storage period is 63 months since the date of manufacturing the Detector.

16.2 The guaranteed period of operation is 60 months since the date of commissioning within the storage period guaranteed.

16.3 For guaranteed maintenance, please contact:

«C.Nord» STCF

Russia, 190020, St. Petersburg,

Obvodny Channel emb., 199-201, build.13, BC «Obvodny Dvor»

Phone: (812) 327-16-36

E-mail: cnord@cnord.ru, support@cnord.ru, www.cnord.ru

Note – Warranty obligations are not applied to the power-supply batteries.

17 Packing Certificate

Wireless passive infrared detector «CN-PIR» manufactured in accordance with current technical documentation is classified as fit for operation and is packed by «RIELTA» JSC.

Packing date _____ month, year