

PREZISS
DIAMANT



HOGGERS

	PAGE
TECHNICAL INFORMATION	28-29
CLASSIC PCD compact hogger	30
ATTACK PLUS PCD compact hogger	31
CLASSIC DUST FLOW PCD compact hogger	32
ATTACK PLUS DUST FLOW PCD compact hogger	33
DFD PCD compact high speed hogger	34
CLASSIC PCD saw blade for hogs	35
ATTACK PLUS PCD saw blade for hogs	36
CLASSIC PCD hogger with saw blade	37
ATTACK PLUS PCD hogger with saw blade	38
Hogging segments in PCD	39
CLASSIC PCD scoring blade for edge trimming machine	40
ATTACK PLUS PCD scoring blade for edge trimming machine	41



HOGGERS

High performance tools designed for board squaring in double end tenoner machines, "Folding" machines, combination machines and special machines.

The mounting of the hogger on the machine shaft is done by means of a simple chuck or hydro centric chuck for high precision.

The following examples offer various uses and work methods.

HOGGER WITH SAW BLADE

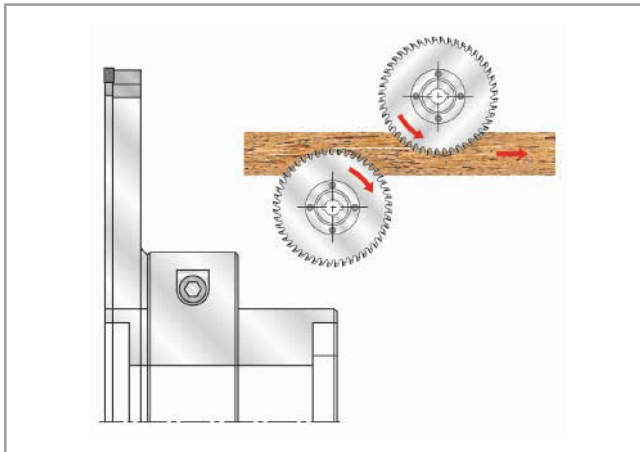

High performance tool, consisting of a saw blade firmly fixed to the hogger element which together with the clamping chuck can be used very effectively in formatting the various parts being manufactured, with the advantage of being able to be used as a saw depending on the work requirements. Suitable for profiling machines.

COMPACT HOGGER

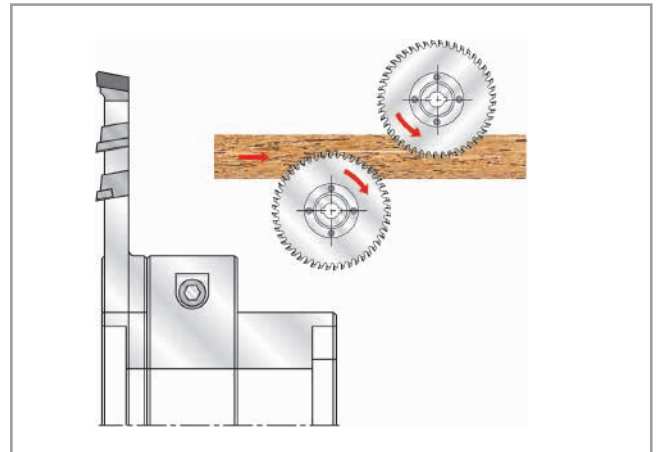

The great strength and stability in its design make the compact hogger with diamond tips the most efficient tool for the formatting of boards with coverings, in double profiling machines and production of edges.

HOGGER FOR FOLDING

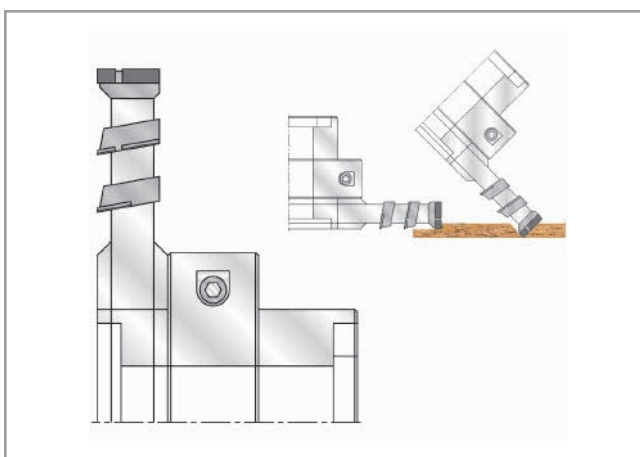

To produce a "V" groove shape with the shaft placed at 45°, to work with boards with coverings used in the manufacturing of furniture carcass, drawers, audio and video furniture, frames, etc.

For mounting on profiling machines or special installations for folding, like: LEHBRINK, KOCH, HOMAG.

SCORING SAW BLADE

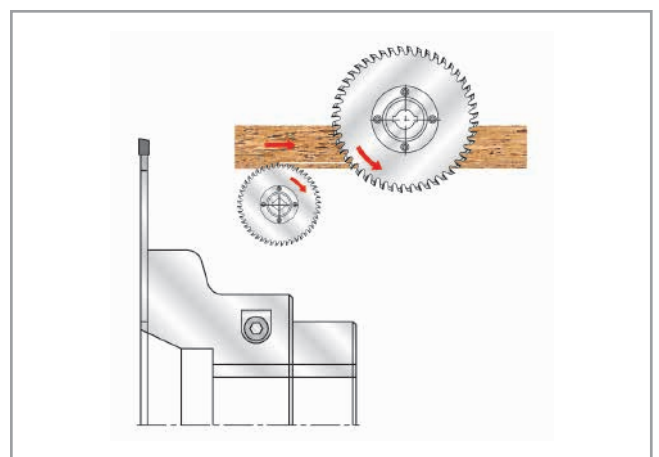

High performance tool, working on boards with hard and abrasive coverings, in profiling machines and edge trimming installations.

It is advisable to mount them on hydrocentric saw blade holder.

HOGGERS

TO ORDER:

Specify the shaft dimensions in order to adapt the suitable hydro centric chuck.

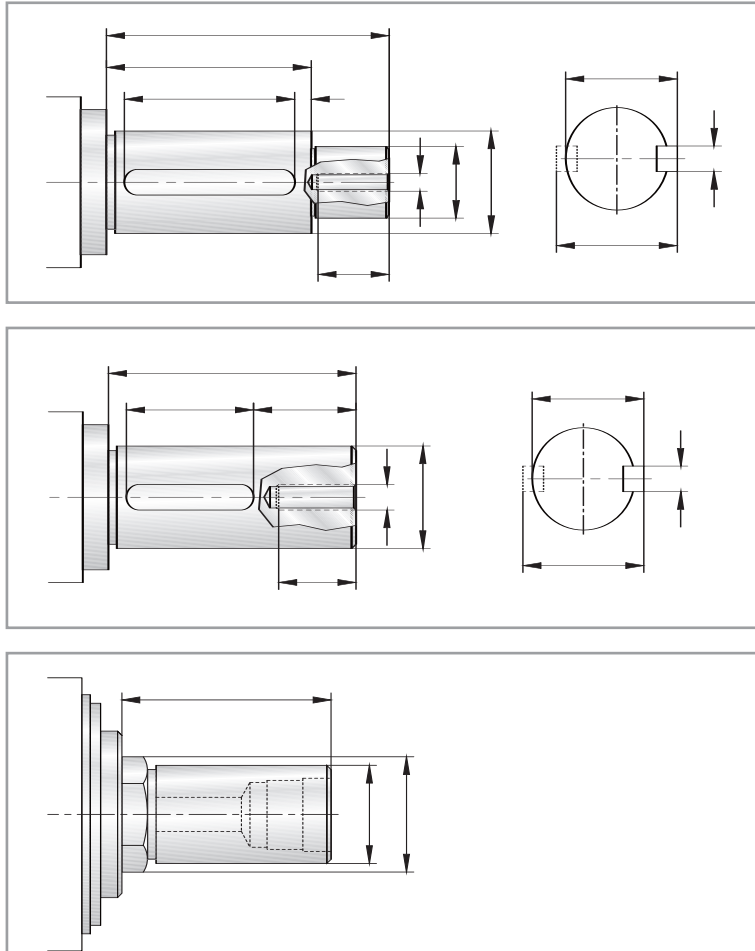
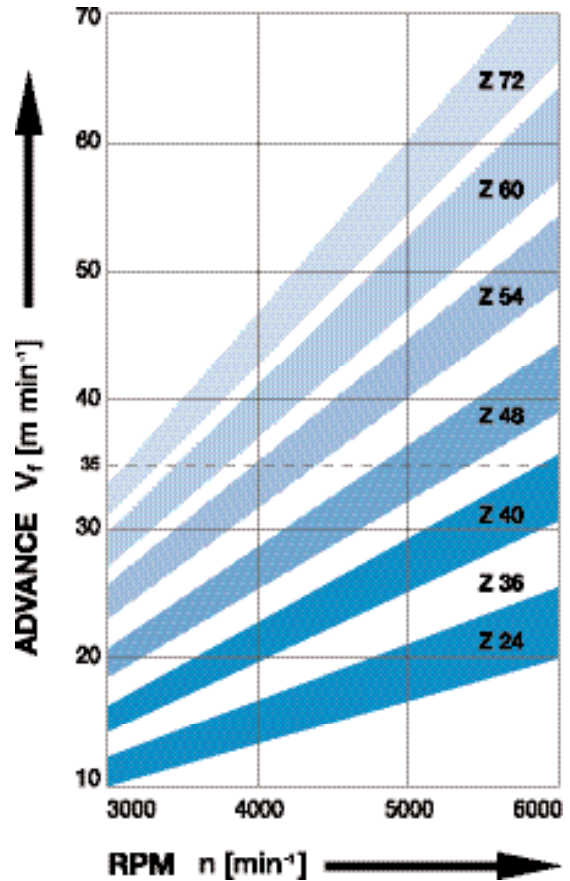

TABLE TO SET THE FEED SPEED

DEPENDING ON THE NUMBER OF TEETH (Z) AND THE MOTOR R.P.M.



20

TYPES OF HOGGER IN ACCORDANCE WITH THE WORK REQUIREMENTS

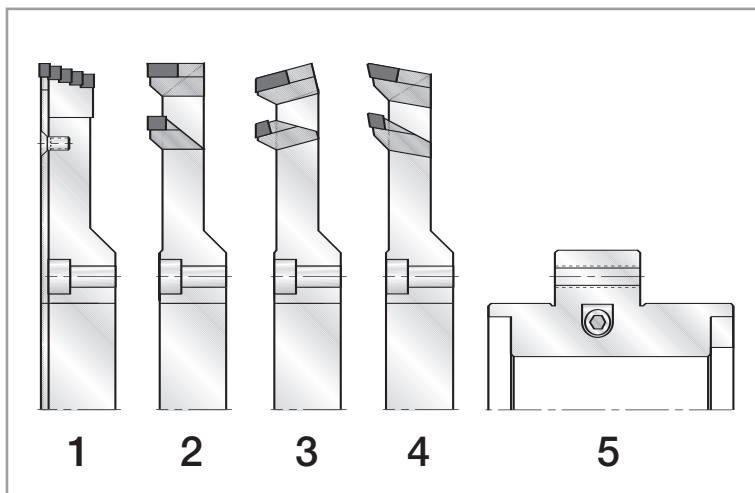

- 1** HOGGER WITH SAW AND SEGMENTS WITH UNIVERSAL D.P.
- 2** FOLDING HOGGER WITH D.P. TIPS
- 3** UP CUTTING HOGGER FOR CROSS CUT/LENGTHWAYS MACHINING WITH PCD TIPS
- 4** DOWN CUTTING HOGGER FOR LONGITUDINAL MACHINING WITH PCD TIPS
- 5** HYDROCENTRIC CHUCK

PCD COMPACT HOGGER

High performance



ØD mm	Ød mm	B mm	Z =	PRODUCT CODE
200	80	11,5	30+6	2001001
200	80	11,5	42+6	2001002
250	80	11,5	42+6	2001003
250	80	11,5	40+20	2001004
250	80	11,5	50+10	2001005
250	80	25	30+6	2001006
200	80	25	42+6	2001007
250	80	25	42+6	2001008
250	80	25	40+20	2001009

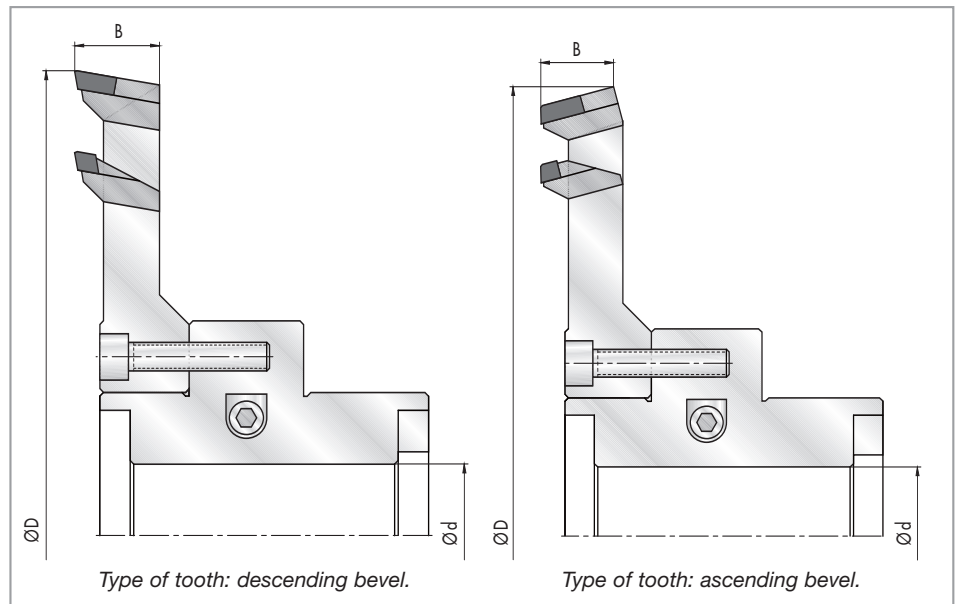

WORKING POSITION

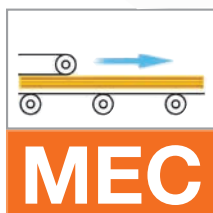
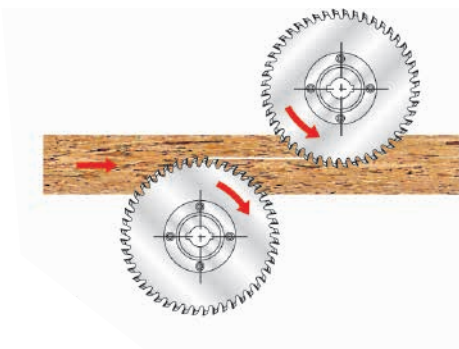

APPLICATION

- Suitable for chipboards and MDF with melamine, paper, HPL, veneers, etc.
- To work on edge trimming machines.

DESCRIPTION

- Cutting with or against the feed.
- Mount on **HYDRO PREZISS** hydro centric models **Series 3** and **Series 5** (see pages 136 and 140), or a standard chuck.

CUT GEOMETRY

- Peripheral angle A: up cut for machining, especially cross cut.
- Peripheral angle D: down cut for longitudinal machining.
- Axial angle and openings between dimensioned teeth, provides problem free dust extraction.

PCD COMPACT HOGGER

Economical



ØD mm	Ød mm	B mm	Z =	PRODUCT CODE
200	80	11,5	30+6	2002001
200	80	11,5	42+6	2002002
250	80	11,5	42+6	2002003
250	80	11,5	40+20	2002004
250	80	11,5	50+10	2002005
250	80	25	30+6	2002006
200	80	25	42+6	2002007
250	80	25	42+6	2002008
250	80	25	40+20	2002009

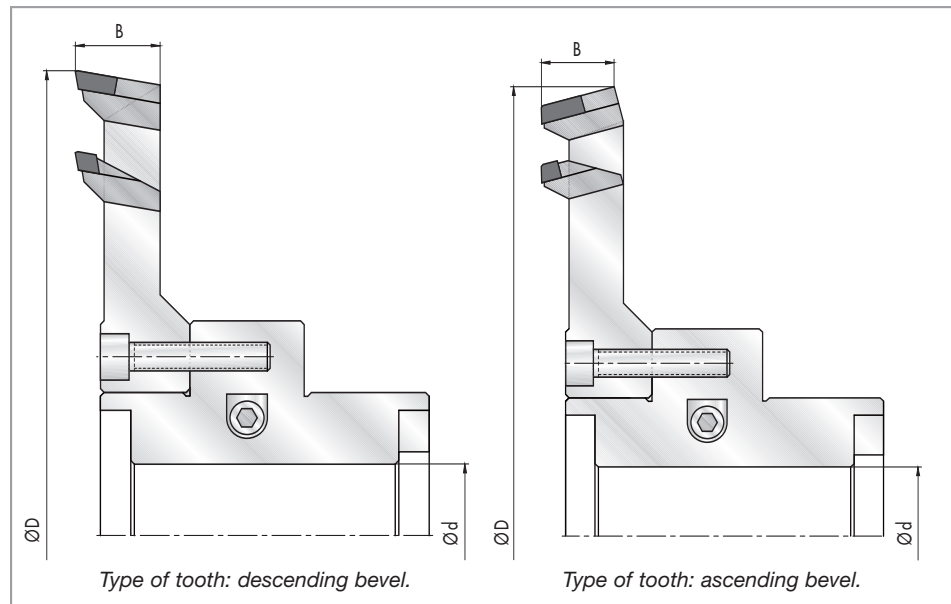

WORKING POSITION

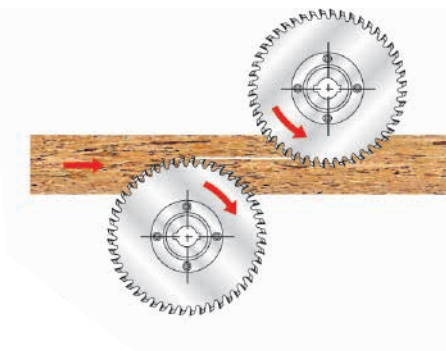

APPLICATION

- Suitable for chipboards and MDF with melamine, paper, HPL, veneer, etc.
- To work on edge trimming machines.

DESCRIPTION

- Cutting with or against the feed.
- Mount on **HYDRO PREZISS** hydro centric models **Series 3** and **Series 5** (see pages 136 and 140), or a standard chuck.

CUT GEOMETRY

- Peripheral angle A: up cut for cross cutting.
- Peripheral angle D: down cut for longitudinal machining.
- Axial angle and tooth spacing allows for better dust extraction.

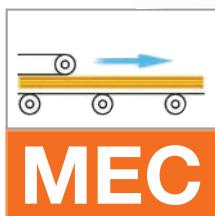

PCD COMPACT HOGGER

High performance



Detail of hogger underside: dust flow.

ØD mm	Ød mm	B mm	Z =	Type	PRODUCT CODE
200	80	11,5	30+6	DFD	2003001
200	80	11,5	42+6	DFD	2003002
250	80	11,5	42+6	DFD	2003003
250	80	11,5	40+20	DFD	2003004
250	80	11,5	50+10	DFD	2003005
250	80	25	30+6	DFD	2003006
200	80	25	42+6	DFD	2003007
250	80	25	42+6	DFD	2003008
250	80	25	40+20	DFD	2003009

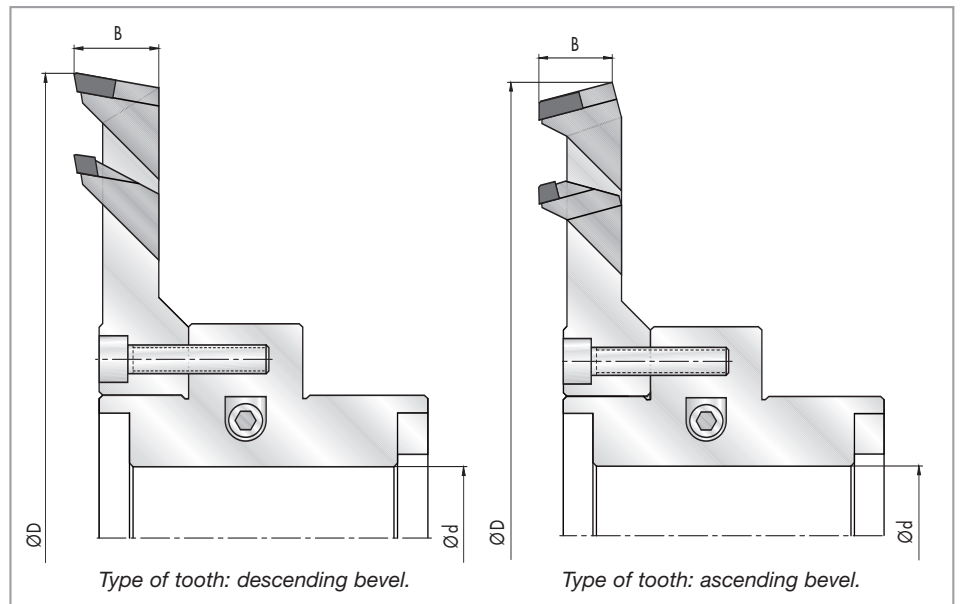

WORKING POSITION

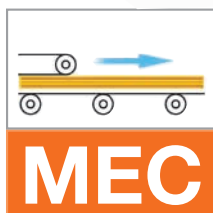
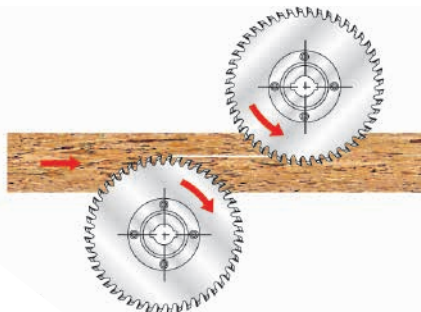

APPLICATION

- Suitable for chipboards and MDF with melamine, paper, HPL, veneers, etc.
- To work on edge trimming machines.

DESCRIPTION

- Cutting with or against the feed.
- Standard design that includes DFD technology for dust control.
- Mount on **HYDRO PREZISS** hydro centric models **Series 3** and **Series 5** (see pages 136 and 140), or a standard chuck.

CUT GEOMETRY

- Peripheral angle A: up cut for cross cutting.
- Peripheral angle D: down cut for lengthways machining.
- Axial angle tooth spacing allows for better dust extraction.

PCD COMPACT HOGGER

Economical



Detail of hogger underside: dust flow.

WORKING POSITION

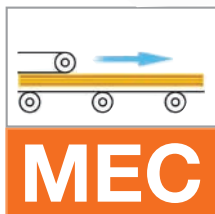
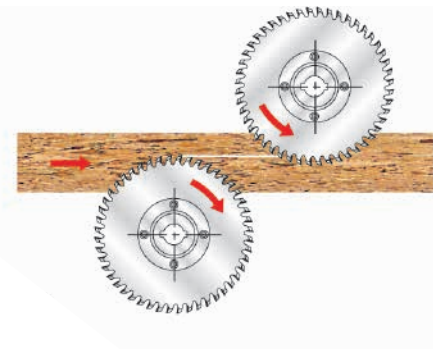

ØD mm	Ød mm	B mm	Z =	Type	PRODUCT CODE
200	80	11,5	30+6	DFD	2004001
200	80	11,5	42+6	DFD	2004002
250	80	11,5	42+6	DFD	2004003
250	80	11,5	40+20	DFD	2004004
250	80	11,5	50+10	DFD	2004005
250	80	25	30+6	DFD	2004006
200	80	25	42+6	DFD	2004007
250	80	25	42+6	DFD	2004008
250	80	25	40+20	DFD	2004009

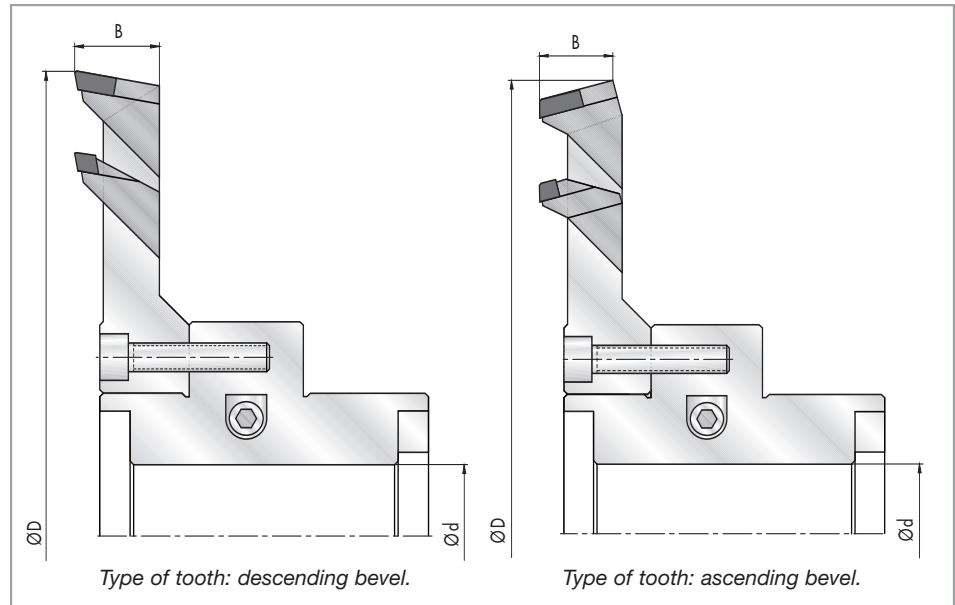

APPLICATION

- Suitable for chipboards and MDF with melamine, paper, HPL, veneer, etc.
- To work on edge trimming machines.

DESCRIPTION

- Cutting with or against the feed.
- Standard design that includes DFD technology for dust control.
- Mount on HYDRO PREZISS hydro centric models Series 3 and Series 5 (see pages 136 and 140), or a standard chuck.

CUT GEOMETRY

- Peripheral angle A: up cut for cross cutting.
- Peripheral angle D: down cut for lengthways machining.
- Axial angle and tooth spacing allows for better dust extraction.

PCD COMPACT HIGH SPEED HOGGER

High performance



ØD mm	Ød mm	B mm	Z =	PRODUCT CODE
250	60/80	14,5/22	12+12	2005001
250	60/80	14,5/22	18+18	2005002
250	60/80	14,5/22	24+24	2005003
250	60/80	14,5/22	28+28	2005004



Detail of teeth.

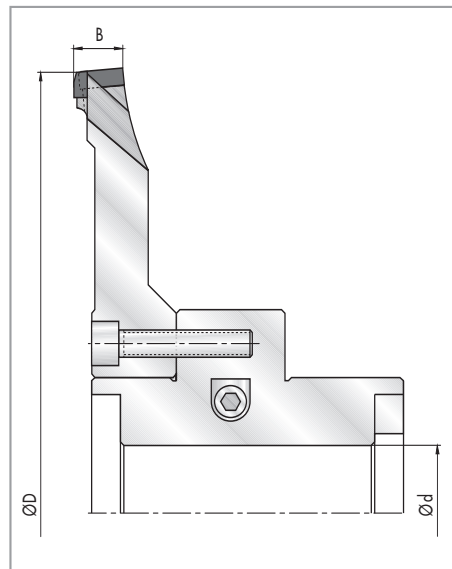

WORKING POSITION

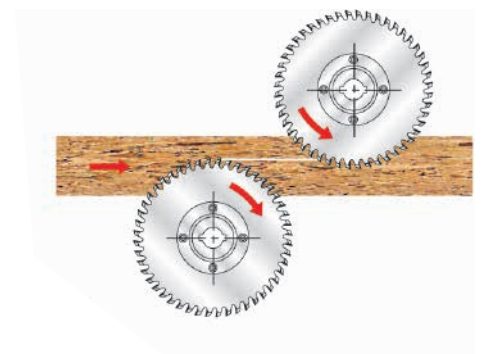

Detail of hogger underside: dust flow.

APPLICATION

- Suitable for chipboards and MDF with melamine, paper, HPL, veneer, etc.
- To work on edge trimming machines with hogger above and below, and a high feed speed.

DESCRIPTION

- Special design that includes the new DUST FLOW technology for dust control and NOISE-REDUCTION system.
- Available in special Polycrystalline Diamond tips.
- It is advisable to mount it on HYDRO PREZISS hydro centric models Series 3 and Series 5 (see pages 136 and 140).

CUT GEOMETRY

- Combines positive and negative attack angles.
- Peripheral angle A: up cut for lengthways and cross cut machining.

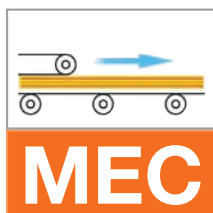

Advance:
 - Z = 18+18
de 20 a 50 m/min.
 - Z = 24+24
de 30 a 70 m/min.
 - Z = 28+28
de 40 a 100 m/min.

PCD SAW BLADE FOR HOGGERS

High performance



ØD mm	Ød mm	B mm	Z =	PRODUCT CODE
200	80	4,0/2,8	36	2006001
200	80	4,0/2,8	40	2006002
200	80	4,0/2,8	42	2006003
200	80	4,0/2,8	48	2006004
200	80	4,0/2,8	60	2006005
200	80	4,0/2,8	64	2006006
200	80	4,0/2,8	72	2006007
250	80	4,0/2,8	36	2006008
250	80	4,0/2,8	40	2006009
250	80	4,0/2,8	42	2006010
250	80	4,0/2,8	48	2006011
250	80	4,0/2,8	60	2006012
250	80	4,0/2,8	64	2006013
250	80	4,0/2,8	72	2006014
300	80	4,0/2,8	48	2006015
300	80	4,0/2,8	72	2006016
300	80	4,0/2,8	98	2006017
350	80	4,0/2,8	60	2006018
350	80	4,0/2,8	72	2006019

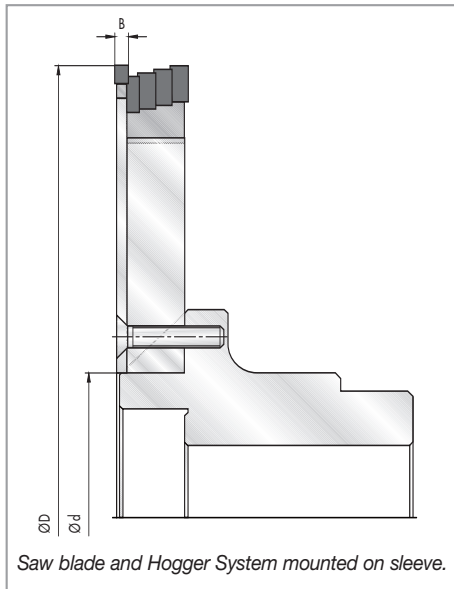
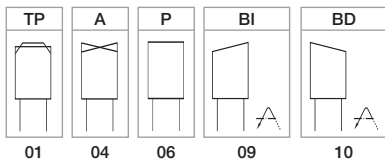

APPLICATION

- Suitable to work on any kind of board, faced or plain, in double profiling machines with double hogging system above and below or with scoring blade.

DESCRIPTION

- High performance and excellent finish quality.
- Replaces conventional tungsten carbide (TCT) saw blade on a hogger.

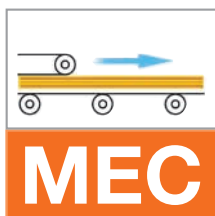

20

PCD SAW BLADE FOR HOGGERS

Economical



ØD mm	Ød mm	B mm	Z =	PRODUCT CODE
200	80	4,0/2,8	36	2007001
200	80	4,0/2,8	40	2007002
200	80	4,0/2,8	42	2007003
200	80	4,0/2,8	48	2007004
200	80	4,0/2,8	60	2007005
200	80	4,0/2,8	64	2007006
200	80	4,0/2,8	72	2007007
250	80	4,0/2,8	36	2007008
250	80	4,0/2,8	40	2007009
250	80	4,0/2,8	42	2007010
250	80	4,0/2,8	48	2007011
250	80	4,0/2,8	60	2007012
250	80	4,0/2,8	64	2007013
250	80	4,0/2,8	72	2007014
300	80	4,0/2,8	48	2007015
300	80	4,0/2,8	72	2007016
300	80	4,0/2,8	98	2007017
350	80	4,0/2,8	60	2007018
350	80	4,0/2,8	72	2007019

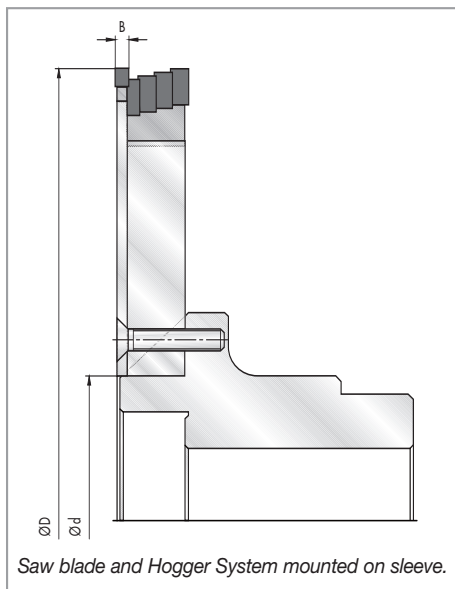
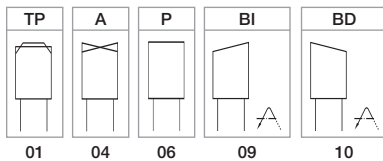

APPLICATION

- Suitable to work on any kind of board, whether faced or plain.

DESCRIPTION

- High performance and excellent finish quality.
- Replaces conventional TCT saw blade on a hogger.

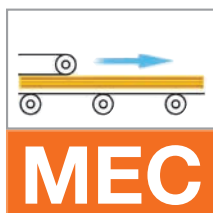

PCD HOGGER WITH SAW BLADE

High performance



ØD mm	B mm	Ød ₁ mm	Ød =	Z =	Segments =	PRODUCT CODE
200	18	35	80	48	4x4	2008001
200	18	40	80	48	4x4	2008002
200	18	35	80	60	4x4	2008003
200	18	40	80	60	4x4	2008004
250	18	35	80	48	6x4	2008005
250	18	40	80	48	6x4	2008006
250	18	35	80	54	6x4	2008007
250	18	40	80	54	6x4	2008008
250	18	35	80	60	6x4	2008009
250	18	40	80	60	6x4	2008010
250	18	35	80	72	6x4	2008011
250	18	40	80	72	6x4	2008012

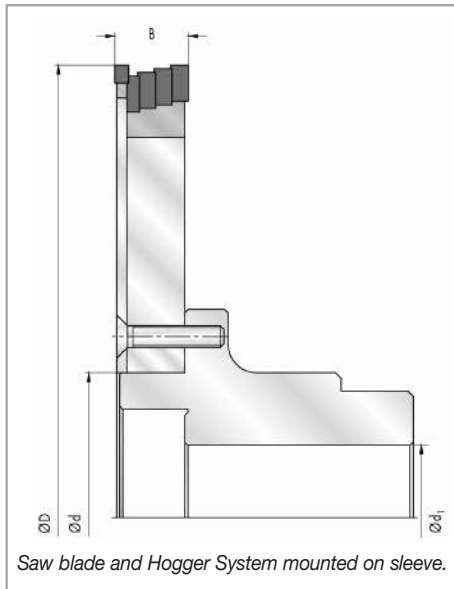
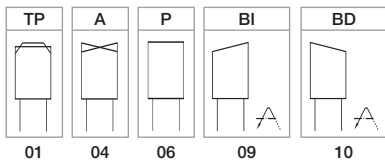

APPLICATION

- In double tenoners, universal machines, multirip saws, etc.
- For the cross cut and lengthways cutting of chipboards, fibre boards, composite materials, edge-glued boards and any material that due to its hardness and abrasiveness needs a tool that offers high durability.

DESCRIPTION

- The most common arrangement in double end tenoners is with scoring blade and hogger against the feed (fig1) or double hogger with the feed (fig 2) and slots in "V grooving" for special folding machines (fig3).
- The set consists of: saw blade, hogging body with PCD tips and clamping unit.
- It is advisable to mount it on **HYDRO PREZISS** hydro centric models Series 3 and Series 5 (see pages 136 and 140).

WORKING POSITION

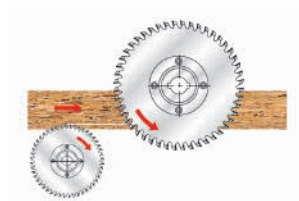

Fig.1 Scoring blade / Shredder

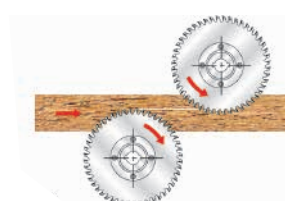

Fig.2 Double shredder

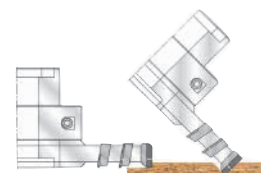
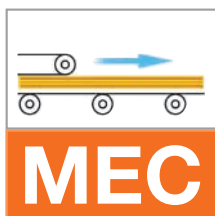

Fig.3 Folding



PCD HOGGER WITH SAW BLADE

Economical



ØD mm	B mm	Ød ₁ mm	Ød =	Z =	Segments =	PRODUCT CODE
200	18	35	80	48	4x4	2009001
200	18	40	80	48	4x4	2009002
200	18	35	80	60	4x4	2009003
200	18	40	80	60	4x4	2009004
250	18	35	80	48	6x4	2009005
250	18	40	80	48	6x4	2009006
250	18	35	80	54	6x4	2009007
250	18	40	80	54	6x4	2009008
250	18	35	80	60	6x4	2009009
250	18	40	80	60	6x4	2009010
250	18	35	80	72	6x4	2009011
250	18	40	80	72	6x4	2009012

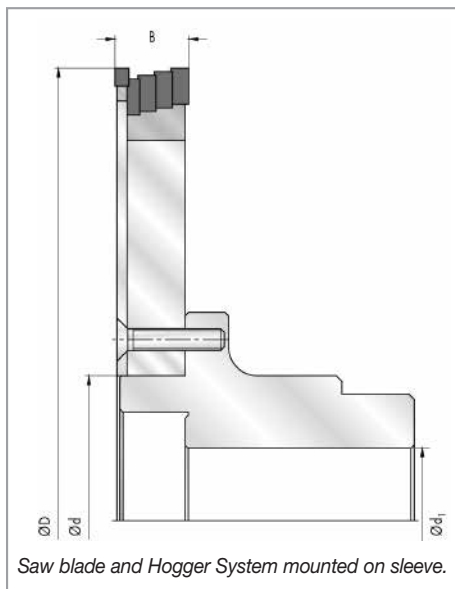
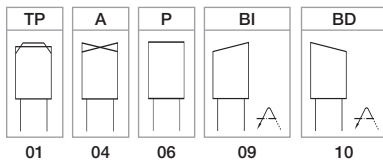

APPLICATION

- In double end tenoners, universal machines, multirip saws, etc.
- For the crosscutting and ripping of chipboards, fibre boards, composite materials, edge-glued boards and any material that due to its hardness and abrasiveness needs a tool that offers high durability.

DESCRIPTION

- The most common arrangement in double end tenoners is with scoring blade and hogger against the feed (fig1) or double hogger with the feed (fig 2) and slots in "V grooving" for special folding machines (fig3).
- The group consists of: saw blade, milling mono-body shredder, with PCD teeth and clamping chuck.
- It is advisable to mount it on **HYDRO PREZISS** hydro centric models **Series 3 and Series 5** (see pages 136 and 140).

WORKING POSITION

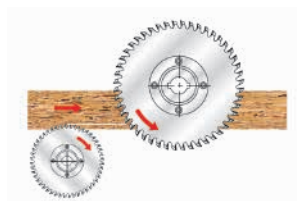
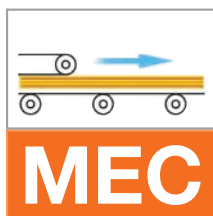

Fig.1 Scoring blade / Shredder

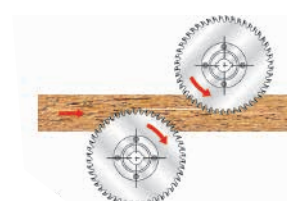
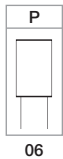
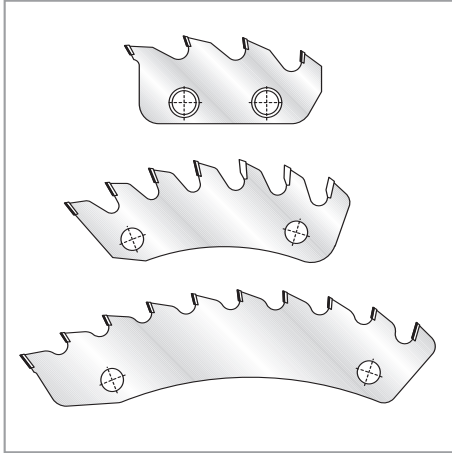

Fig.2 Double shredder



Fig.3 Folding

HOGGING SEGMENTS IN PCD



for ØD mm	Z =	Right R	Left L	PRODUCT CODE
200	4	x		2010001
200	4		x	2010002
250	4	x		2010003
250	4		x	2010004
FOR SPECIAL HOGGERS				
for ØD mm	Z =	Right R	Left L	PRODUCT CODE
250	6	x		2010021
250	6		x	2010022
300	6	x		2010023
300	6		x	2010024
350	6	x		2010025
350	6		x	2010026
300	10	x		2010027
300	10		x	2010028
350	10	x		2010029
350	10		x	2010030
250	7	x		2010031
250	7		x	2010032
300	9	x		2010033
300	9		x	2010034
350	12	x		2010035
350	12		x	2010036
350	16	x		2010037
350	16		x	2010038

20

APPLICATION

- For replacement of conventional low performance TCT hogsers.

DESCRIPTION

- High performance when working with very abrasive materials.

NOTE

- When ordering, we advise you to send a sample or drawing with the measurements, number of teeth, drill anchorage, model and brand of the hogger that you want to replace.

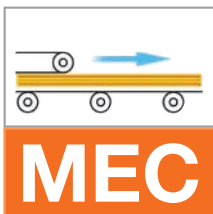

PCD SCORING BLADE FOR EDGE TRIMMING MACHINE

High performance



ØD mm	Ød mm	B mm	Z =	PRODUCT CODE
150	30/65	3,2	24	2011001
150	30/65	3,2	36	2011002
150	30/65	3,2	48	2011003
180	30/65	3,2	36	2011004
180	30/65	3,2	48	2011005
180	30/65	3,2	54	2011006
200	30/65	3,2	48	2011007
200	30/65	3,2	64	2011008

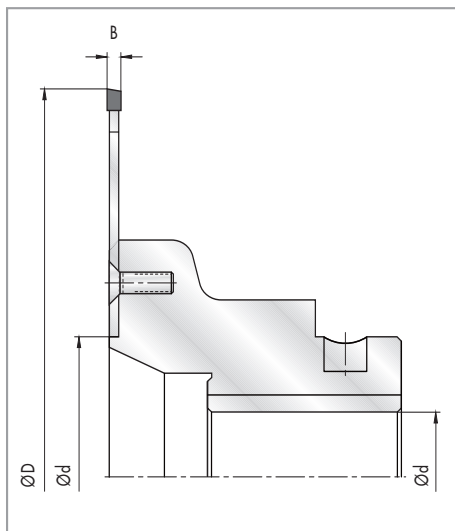
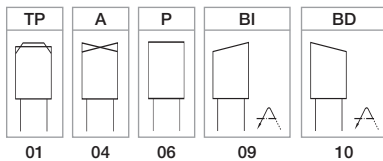

APPLICATION

- In double end tenoners, universal and special machines.
- Specially recommended for working with a hogger on materials such as chipboards and MDF with melamine, paper, HPL, veneer, etc. with a very good underside finish.

DESCRIPTION

- For work combined with hogs (*fig1*).
- Clamp directly to the shaft by means of screws or alternatively by clamping chuck or HYDRO PREZISS hydro centric chucks Series 3 and Series 5 (see pages 136 and 140).

WORKING POSITION

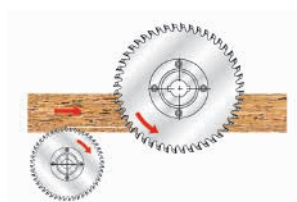
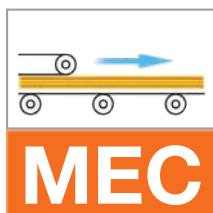

Fig.1 Scoring blade / Shredder

PCD SCORING BLADE FOR EDGE TRIMMING MACHINE

Economical



ØD mm	Ød mm	B mm	Z =	PRODUCT CODE
150	30/65	3,2	24	2012001
150	30/65	3,2	36	2012002
150	30/65	3,2	48	2012003
180	30/65	3,2	36	2012004
180	30/65	3,2	48	2012005
180	30/65	3,2	54	2012006
200	30/65	3,2	48	2012007
200	30/65	3,2	64	2012008

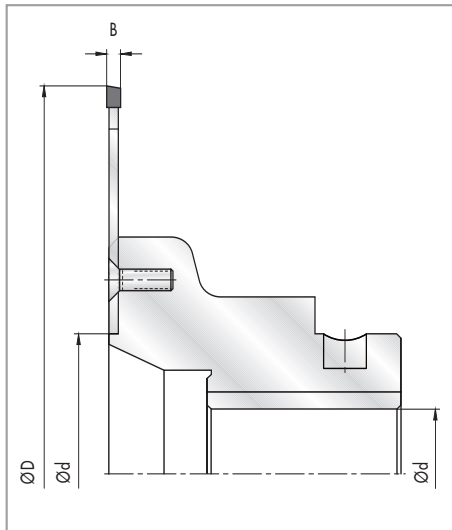
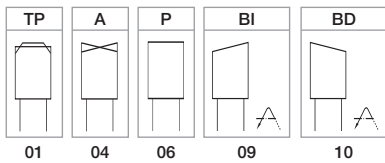

APPLICATION

- In double end tenoners, universal and special machines.
- Specially recommended to work together with a hogger on materials such as chipboards and MDF with melamine, paper, HPL, veneer, etc. with a very good underside finish.

DESCRIPTION

- For work combined with hoggers (*fig1*).
- Clamp directly to the shaft by means of screws or alternatively by clamping chuck or **HYDRO PREZISS** hydro centric chucks Series 3 and Series 5 (see pages 136 and 140).

WORKING POSITION

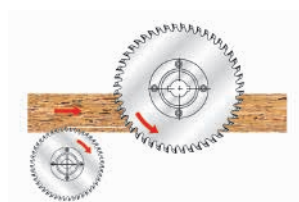

Fig.1 Scoring blade / Shredder

