



INSTALLATION INSTRUCTIONS

For all styles of Croft PREHUNG Aluminum Storm doors



FOR HELP WITH INSTALLATION AND/OR MISSING OR DEFECTIVE PARTS,
CALL TOLL FREE 1-800-222-3195

TOOLS REQUIRED

1. One standard flat blade screwdriver
2. One No. 2 Phillips Head screwdriver
3. One hacksaw
4. One knife or scissors
5. Tape measure or rule

DO NOT ATTEMPT TO INSTALL DOOR UNTIL YOU DO THE FOLLOWING:

1. Inspect door for possible shipping damage.
2. Make certain it is hinged on desired side.
3. Check actual door measurements with opening measurements.

YOU ARE NOW READY TO INSTALL THE DOOR:

DO NOT remove shipping clip (B) at this time.

STEP 1: Carefully measure door opening height and mark Z-bar jambs accordingly. Z-bars are oversize. Measure from head, and cut off lower (sill) end. Cut at angle to match threshold pitch. If sill expander interferes with sawing off Z-bars, remove temporarily.

STEP 2: Insert door in opening allowing Z-bar jambs to support weight of door. Center door in opening so that Z-bars have equal overlap and secure by running installation screws through holes in Z-bar flanges.

STEP 3: You may now remove the shipping clips by removing screws (A). This will allow door to swing open. With door in open position, remove shipping clips (B) from door jamb by loosening screws (C) and disengaging clip, retighten screws. (FIG. 2) Clips may now be thrown away. Use remaining installation screws in holes exposed in Z-bar by removal of shipping clips. Open door and insert the flat head wood screw in holes located on inside of Z-bar jamb behind hinges. **NOTE: If there is a gap between z-bar jamb and door opening be sure to use shim blocks at screw locations for support.** If you removed the sill expander, replace it at this time with the door open.

STEP 4: All styles except 161, 175 and 461, close door and adjust sill expander downward until the Vinyl door sweep makes a good weatherseal with threshold (FIG. 3).

STEP 5: Your door is completely prepared for all hardware attachment. Install hardware as per instructions included.

For DARK BRONZE, COLONIAL WHITE or SATIN BLACK FINISH: To preserve the beautiful finish, wash door with a detergent and warm water, rinse thoroughly, apply a coat of automotive wax.

For NATURAL ALUMINUM FINISH: Clean with household soap pads to bright finish, apply automotive wax.

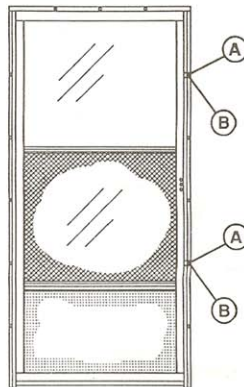

Figure 1

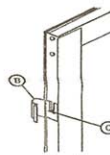

Figure 2

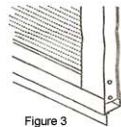
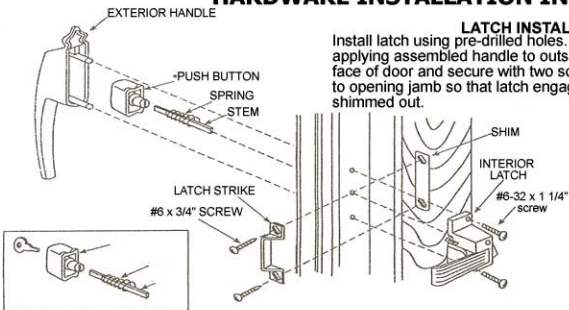

Figure 3

COMBINATION STORM & SCREEN DOOR HARDWARE INSTALLATION INSTRUCTIONS

LATCH INSTALLATION

Install latch using pre-drilled holes. Assemble in sequence as shown applying assembled handle to outside of door. Line up latch to inner face of door and secure with two screws provided. Attach latch strike to opening jamb so that latch engages properly. Strike may have to be shimmed out.



NOTE: After the door has been installed plumb and true and sill sweep has been adjusted to the proper height, see that the door opens and closes freely.

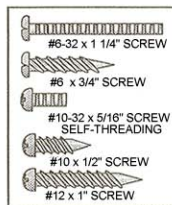



INSTALLATION INSTRUCTIONS

For all styles of Croft PREHUNG Aluminum Storm doors



FOR HELP WITH INSTALLATION AND/ OR MISSING OR DEFECTIVE PARTS,
CALL TOLL FREE 1-800-222-3195

CLOSER INSTALLATION

Determine whether closer is to be mounted at top of door or at the meeting rail of door by matching the style number of your door to the style number listed on the reverse side.

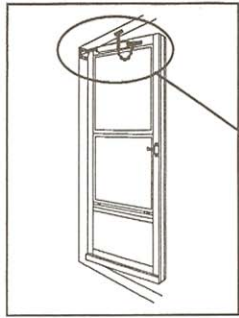

SEE DETAIL "A"
(ON BACK)

**CLOSER
INSTALLATION
AT TOP**

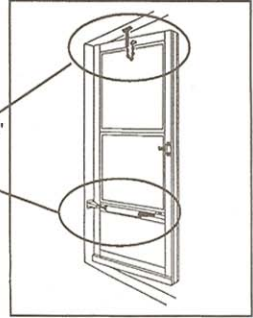

SEE DETAIL "C"
(ON BACK)

SEE DETAIL "B"
(ON BACK)

**CLOSER
INSTALLATION
AT MEETING
RAIL**

TOP OF DOOR CLOSER INSTALLATION

For Installation of Styles: 163, 265, 466, 562, 563, 469, 567.

Closer mounts to top of door header by mounting jamb bracket to hinge side of wood jamb 1/4" "inward" from door aligning with door header. Be sure open side of bracket faces storm door. Slide hold-open washer on rod. Using short connecting pin, connect closer to jamb bracket. Hold-open washer should be positioned over lugs against closer tube as shown. This will give proper tension for installation. (Do not change until installation is complete.)

Attach door bracket to closer tube front hole with long connecting pin. With door tightly closed, fasten to door with the #10 x 1/2" screws provided. **NOTE: If you have a reversible storm door you must match drill these holes with door bracket using a 1/8" bit.**

Attach chain to door bracket with long connecting pin. Locate other end of chain assembly to top of door opening so that chain will stop door at 90° opening. Move hold-open washer to back of lugs on rod and adjust speed by regulating screw on closer end for desired closing speed.

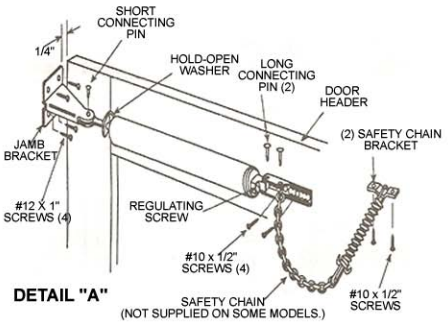

DETAIL "A"



INSTALLATION INSTRUCTIONS

For all styles of Croft PREHUNG Aluminum Storm doors



FOR HELP WITH INSTALLATION AND/ OR MISSING OR DEFECTIVE PARTS,
CALL TOLL FREE 1-800-222-3195

MEETING RAIL CLOSER INSTALLATION

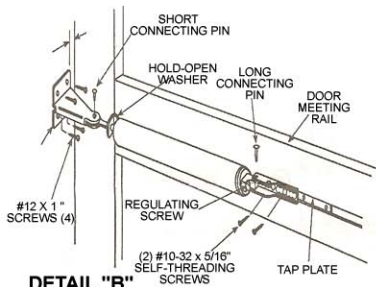

For Installation of Styles: 161, 175, 262, 264, 266, 461, 464, 471, 564, 575.

Closer mounts to meeting rail by mounting jamb bracket to hinge side of wood jamb 1/4" "inward" from door as shown. Be sure open side of bracket faces storm door. Slide hold-open washer on rod. Using short connecting pin, connect closer to jamb bracket. Hold-open washer should be positioned over lugs against closer tube as shown. This will give proper tension for installation. (Do not change until installation is complete.) Attach door bracket to closer tube front hole with long connecting pin. With door tightly closed locate properly at meeting rail. Align tap plate and secure with #10-32 x 5/16" self-threading screws. Move hold-open washer to back of lugs on rod and adjust speed by regulating screw on closer end for desired closing speed.

SAFETY CHAIN INSTALLATION

(WHEN CLOSER IS INSTALLED AT MEETING RAIL)
(NOT SUPPLIED ON SOME MODELS)

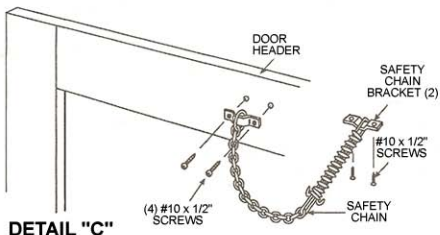

Attach chain end and bracket to door header using pre-punched holes. If you have a reversible door you will need to drill these holes. Locate first hole 14" from hinge jamb, and the second hole 3/4" from the first. Locate other end of chain assembly to top of opening so that chain stops door at 90° opening.

NOTE: Styles 161, 175 & 461 do not include a safety chain.